

SLV-SE10/SE20/SE25/SE30/SE40/SE45/SX10/SX25/SX40 RMT-V256/V256A/V257/V257A/V257B/V257C/V259

SERVICE MANUAL



Photo: SLV-SE45
RMT-V259

VHS

S MECHANISM

AEP Model

SLV-SE10AE1/SE10AE2

UK Model

SLV-SE20UX/SE30UX/SE45UX

French Model

SLV-SE25B/SE40B

German Model

SLV-SE20VP1/SE20VP2/SE25VC

/SE30VC1/SE30VC2/SE40VC1

/SE40VC2/SE45VC/SX25VC

Spanish Model

SLV-SE25CP/SE30CP/SE40CP/SE45CP

East European Model

Greek Model

SLV-SE10EE/SE10EG/SE30EE/SE40EE/
SE40EG/SX10EG/SX40EG

Irish Model

SLV-SE20EX

Refer to the SERVICE MANUAL of VHS
MECHANICAL ADJUSTMENT VI for
MECHANICAL ADJUSTMENTS. (9-921-647-11)

SPECIFICATIONS

System

Channel coverage(10EE/EG/30EE/40EE/EG/
X10/X40 MODEL)

PAL(B/G,D/K):

VHF E2 to E12,R1 to R12

UHF E21 to E69,R21 to R69

CATV S1 to S41,S01 to S05

PAL(B/G):(10AE1/AE2/40B/25B/45CP/
30CP/VC1/VC2/20VP1/VP2/25CP/VC/40CP/
VC1/VC2/45VC/X25 MODEL)

VHF E2 to E12

VHF Italian channels A to H

UHF E21 to E69

CATV S01 to S05,S1 to S20

HYPER S21 to S41

SECAM(L):(SE25B/40B MODEL)

VHF F2 to F10

UHF F21 to F69

CATV B to Q

HYPER S21 to S41

PAL(B/G):

VHF E2 to E12

VHF Italian channels A to H

UHF E21 to E69

CATV S01 to S05,S1 to S20

HYPER S21 to S41

PAL (I)(20EX/UX MODEL)

VHFIA to IJ,SA10 to SA13(20EX only)

UHF B21 to B69

CATV S01 to S05,S1 to S20(20EX only)

HYPER S21 to S41

PAL (I)(SE30UX/45UX MODEL)

UHF B21 to B69

RF output signal

UHF channels 21 to 69

Aerial out

75-ohm asymmetrical aerial socket

Inputs and outputs

LINE-1

(TV)

21-pin

Video input: pin 20

Audio input: pins 2 and 6

Video output: pin 19

Audio output: pins 1 and 3

LINE-2 1N(10EE/30CP/VC1/VC2/EE/UX/
45CP/UX MODEL)

VIDEO IN, phono jack (1)

Input signal: 1 Vp-p,

75 ohms, unbalanced, sync negative

AUDIO IN,

phono jack (1)

Input level: 327 mVrms

Input impedance : more than 47 kilohms

LINE-2 IN(SE25VC/40VC1 MODEL)

21-pin

Video input: pin 20

Audio input: pins 2 and 6

LINE-2 IN

(25B/CP/VC/UX/40B/CP/VC1/VC2/45VC/
UX/X25 MODEL)

LINE-3 IN

(30CP/VC1/UX/VC2/45CP/UX)

21-pin

Video input: pin 20

Audio input: pins 2 and 6

LINE OUT(10EE/30EE/40EE)

AUDIO OUT,Phono jack(2)

Rated output level:327mVrms

Load impedance:47 kilohms

Output impedance:less than 10 kilohms

VIDEO OUT,Phono jack(1)

Rated output level:327mVrms

Load impedance:47 kilohms

Output impedance:less than 10 kilohms

General

Power requirements

220 - 240 V AC, 50 Hz

Power consumption

22 W

Operating temperature

5°C to 40°C

Storage temperature

-20°C to 60°C

Dimensions

Approx. 355 x 96 x 285 mm(w/h/d)

including projecting parts and controls

Mass

Approx. 3.8 kg

(Approx. 10 lb 2 oz)

Supplied accessories

Remote commander (1)

R6 (size AA) batteries (2)

Aerial cable (1)

AC Plug adaptor(1)(20EX/UX)

Design and specifications are subject to change without notice.

VIDEO CASSETTE RECORDER



SONY®

SAFETY-RELATED COMPONENT WARNING!!

COMPONENTS IDENTIFIED BY MARK \triangle OR DOTTED LINE WITH MARK \triangle ON THE SCHEMATIC DIAGRAMS AND IN THE PARTS LIST ARE CRITICAL TO SAFE OPERATION. REPLACE THESE COMPONENTS WITH SONY PARTS WHOSE PART NUMBERS APPEAR AS SHOWN IN THIS MANUAL OR IN SUPPLEMENTS PUBLISHED BY SONY.

ATTENTION AU COMPOSANT AYANT RAPPORT À LA SÉCURITÉ!

LES COMPOSANTS IDENTIFIÉS PAR UNE MARQUE \triangle SUR LES DIAGRAMMES SCHÉMATIQUES ET LA LISTE DES PIÈCES SONT CRITIQUES POUR LA SÉCURITÉ DE FONCTIONNEMENT. NE REMPLACER CES COMPOSANTS QUE PAR DES PIÈCES SONY DONT LES NUMÉROS SONT DONNÉS DANS CE MANUEL OU DANS LES SUPPLÉMENTS PUBLIÉS PAR SONY.

SAFETY CHECK-OUT

After correcting the original service problem, perform the following safety checks before releasing the set to the customer.

1. Check the area of your repair for unsoldered or poorly-soldered connections. Check the entire board surface for solder splashes and bridges.
2. Check the interboard wiring to ensure that no wires are "pinched" or contact high-wattage resistors.
3. Look for unauthorized replacement parts, particularly transistors, that were installed during a previous repair. Point them out to the customer and recommend their replacement.
4. Look for parts which, through functioning, show obvious signs of deterioration. Point them out to the customer and recommend their replacement.
5. Check the B+ voltage to see it is at the values specified.
6. Flexible Circuit Board Repairing
 - Keep the temperature of the soldering iron around 270°C during repairing.
 - Do not touch the soldering iron on the same conductor of the circuit board (within 3 times).
 - Be careful not to apply force on the conductor when soldering or unsoldering.

FEATURE DIFFERENCE

MODEL NAME		SE10AE1	SE10AE2	SE10EE	SE10EG	SE20EX	SE20UX	SE20VP1	SE20VP2	SE25B
BASE	4Head VIDEO									
	LP REC					○	○			
	NTSC (REC/PB)			×/○	×/○	×/○	×/○	×/○	×/○	×/○
	PAL (REC/PB)	○/○	○/○	○/○	○/○	○/○	○/○	○/○	○/○	○/○
	SECAM(REC/PB)									○/○
	ME-SECAM(REC/PB)			○/○	○/○					×/○
	BODY COLOR(TV BLACK)					○	○			
PANEL	SOCCER	○	○	○	○	○	○	○	○	○
	CLICK SHUTTLE									
	CLICK SHUTTLE(JOG)									
SW	NT PB ON PAL TV/4.43PB			○2	○2	○2	○2	○2	○2	○2
	RF OFF	○ OSD	○ OSD		○ OSD	○ OSD	○ OSD	○ OSD	○ OSD	○ OSD
	SIMULATED STEREO									
I/O	LINE1 RCA or EUR	EUR	EUR	RCA	EUR	EUR	EUR	EUR	EUR	EUR
	FRONT IN									
	EUR IN (2nd)									
	C+ (2nd)									○ (SW, C+)
MEDIA	SMARTLINK					○	○	○	○	○
	VCR+/G-code/Show V/V+					VPLUS	VPLUS	ShowV	ShowV	ShowV
	ACS (Δ : ACA)						○	Δ	Δ	○
	PDC/VPS					PDC/VPS	PDC/VPS	PDC/VPS	PDC/VPS	PDC/VPS
	ITP					○	○	○	○	○
	AUTO LONG PLAY					○	○			
	SECURITY FUNCTION					○	○			
VIDEO	CTL MUTE	○	○	×	×	○	○	○	○	○
	APC	2○	2○	2○	2○	2○	2○	2○	2○	2○
	LONG LIFE HEAD	○	○	○	○			○	○	○
TUNER	SYSTEM 1	BG	BG	DK	DK	I	I	BG	BG	L
	STEREO									
	SYSTEM 2			BG	BG					BG
	CATV	○	○	○	○	○		○	○	○
	RF OUT SYS	G	G	K/G	K/G	I	I	G	G	L/G
	CH	PLL	PLL	PLL	PLL	PLL	PLL	PLL	PLL	PLL
	CH	21 to 69	21 to 69	21 to 69	21 to 69	21 to 69	21 to 69	21 to 69	21 to 69	21 to 69
AUDIO	SIMULATED STEREO									
FUNCTION	POWER SAVE(OSD)	○	○		○	○	○	○	○	○
	INDEX SEARCH(RMT)									
ACCESSORY	AC Plug Adaptor					○	○			
REMOTE COMMANDER		RMT-V256	RMT-V256	RMT-V256	RMT-V256	RMT-V257B	RMT-V257B	RMT-V257	RMT-V257	RMT-V257A

MODEL NAME		SE25CP	SE25VC	SE30CP	SE30EE	SE30UX	SE30VC1	SE30VC2	SE40B	SE40CP
BASE	4Head VIDEO								○	○
	LP REC	○	○	○		○	○	○	○	○
	NTSC (REC/PB)	×/○	×/○	×/○	×/○	×/○	×/○	×/○	×/○	×/○
	PAL (REC/PB)	○/○	○/○	○/○	○/○	○/○	○/○	○/○	○/○	○/○
	SECAM(REC/PB)								○/○	
	ME-SECAM(REC/PB)				○/○				×/○	
	BODY COLOR(TV BLACK)					○				
PANEL	SOCCER	○	○	○		○	○	○	○	○
	CLICK SHUTTLE				○					
	CLICK SHUTTLE(JOG)									
SW	NT PB ON PAL TV/4.43PB	○2	○2	○2	○2	○2	○2	○2	○2	○2
	RF OFF	○ OSD	○ OSD	○ OSD		○ OSD	○ OSD	○ OSD	○ OSD	○ OSD
	SIMULATED STEREO				○					
I/O	LINE1 RCA or EUR	EUR	EUR	EUR	RCA	EUR	EUR	EUR	EUR	EUR
	FRONT IN			○	○	○	○	○		
	EUR IN (2nd)					○				
	C+ (2nd)	○ (SW, C+)	○ (SW, C+)	○ (SW, C+)			○ (SW, C+)	○ (SW, C+)	○ (SW, C+)	○ (SW, C+)
MEDIA	SMARTLINK	○	○	○		○	○	○	○	○
	VCR+/G-code/Show V/V+	ShowV	ShowV	ShowV		VPLUS	ShowV	ShowV	ShowV	ShowV
	ACS (Δ : ACA)		Δ			○	Δ	Δ	○	
	PDC/VPS		PDC/VPS			PDC/VPS	PDC/VPS	PDC/VPS	PDC/VPS	
	ITP		○			○	○	○	○	
	AUTO LONG PLAY	○	○	○		○	○	○	○	○
	SECURITY FUNCTION					○				
VIDEO	CTL MUTE	○	○	○	×	○	○	○	○	○
	APC	2○	2○	2○	2○	2○	2○	2○	3○	3○
	LONG LIFE HEAD				○					
TUNER	SYSTEM 1	BG	BG	BG	DK	I	BG	BG	L	BG
	STEREO									
	SYSTEM 2				BG				BG	
	CATV	○	○	○	○		○	○	○	○
	RF OUT SYS	G	G	G	K/G	I	G	G	L/G	G
	CH	PLL	PLL	PLL	PLL	PLL	PLL	PLL	PLL	PLL
	CH	21 to 69	21 to 69	21 to 69	21 to 69	21 to 69	21 to 69	21 to 69	21 to 69	21 to 69
AUDIO	SIMULATED STEREO				○					
FUNCTION	POWER SAVE(OSD)	○	○	○		○	○	○	○	○
	INDEX SEARCH(RMT)			○		○	○	○		
ACCESSORY	AC Plug Adaptor					○				
REMOTE COMMANDER		RMT-V257B	RMT-V257B	RMT-V259	RMT-V256	RMT-V259	RMT-V259	RMT-V259	RMT-V257C	RMT-V257B

MODEL NAME		SE40EE	SE40EG	SE40VC1	SE40VC2	SE45CP	SE45UX	SE45VC	SX10EG	SX25VC	SX40EG
BASE	4Head VIDEO	○	○	○	○	○	○	○			○
	LP REC	○	○	○	○	○	○	○		○	○
	NTSC (REC/PB)	×/○	×/○	×/○	×/○	×/○	×/○	×/○	×/○	×/○	×/○
	PAL (REC/PB)	○/○	○/○	○/○	○/○	○/○	○/○	○/○	○/○	○/○	○/○
	SECAM(REC/PB)										
	ME-SECAM(REC/PB)	○/○	○/○						○/○		○/○
	BODY COLOR (TV BLACK)						○		○		○
PANEL	SOCCER	○	○	○	○				○	○	○
	CLICK SHUTTLE										
	CLICK SHUTTLE(JOG)					○	○	○			
SW	NT PB ON PAL TV/4.43PB	○2	○2	○2	○2	○2	○2	○2	○2	○2	○2
	RF OFF		○ OSD	○ OSD	○ OSD	○ OSD	○ OSD	○ OSD	○ OSD	○ OSD	○ OSD
	SIMULATED STEREO										
I/O	LINE1 RCA or EUR	RCA	EUR	EUR	EUR	EUR	EUR	EUR	EUR	EUR	EUR
	FRONT IN					○	○	○			
	EUR IN (2nd)						○				
	C+ (2nd)			○ (SW, C+)	○ (SW, C+)	○ (SW, C+)		○ (SW, C+)		○ (SW, C+)	
MEDIA	SMARTLINK		○	○	○	○	○	○		○	
	VCR+/G-code/Show V/V+		Show V	Show V	Show V	Show V	VPLUS	Show V		Show V	
	ACS (Δ : ACA)		Δ	Δ	○		○	Δ		Δ	
	PDC/VPS		PDC/VPS	PDC/VPS	PDC/VPS		PDC/VPS	PDC/VPS		PDC/VPS	
	ITP		○	○	○		○	○		○	
	AUTO LONG PLAY	○	○	○	○	○	○	○		○	○
	SECURITY FUNCTION						○				
	CTL MUTE	×	×	○	○	○	○	○	×	○	×
VIDEO	APC	3○	3○	3○	3○	3○	3○	3○	2○	2○	3○
	LONG LIFE HEAD								○		
TUNER	SYSTEM 1	DK	DK	BG	BG	BG	I	BG	DK	BG	DK
	STEREO										
	SYSTEM 2	BG	BG						BG		BG
	CATV	○	○	○	○	○		○	○	○	○
	RF OUT SYS	K/G	K/G	G	G	G	I	G	K/G	G	K/G
	CH	PLL	PLL	PLL	PLL	PLL	PLL	PLL	PLL	PLL	PLL
	CH	21 to 69	21 to 69	21 to 69	21 to 69	21 to 69	21 to 69	21 to 69	21 to 69	21 to 69	21 to 69
AUDIO	SIMULATED STEREO										
FUNCTION	POWER SAVE(OSD)		○	○	○	○	○	○	○	○	○
	INDEX SEARCH(RMT)					○	○	○			
ACCESSORY	AC Plug Adaptor						○				
REMOTE COMMANDER		RMT-V256A	RMT-V257B	RMT-V257B	RMT-V257B	RMT-V259	RMT-V259	RMT-V259	RMT-V256	RMT-V257B	RMT-V257B

TABLE OF CONTENTS

SERVICE NOTE	
1. ERROR CODE INDICATION	7
1. GENERAL	
Getting Started	
Unpacking	1-1
Setting up the remote commander	1-1
Connecting the VCR	1-2
Setting up the VCR with the Auto Set Up function	1-3
Tuning your TV to the VCR	1-3
Selecting a language	1-4
Presetting channels	1-4
Changing/disabling programme positions	1-5
Setting the clock	1-6
Setting your personal code	1-8
Basic Operations	
Playing a tape	1-8
Recording TV programmes	1-9
Recording TV programmes using the VIDEO Plus+ system	1-10
Setting the timer manually	1-11
Additional Operations	
Playing/searching at various speeds	1-12
Setting the recording duration time	1-13
Checking/changing/cancelling timer settings	1-13
Searching using the Smart Search function	1-14
Seatching using the index function	1-14
Adjusting the picture	1-15
Changing menu options	1-15
Editing with another VCR	1-16
Additional Information	
Index to parts and controls	1-16
2. DISASSEMBLY	
2-1. CASE, FRONT PANEL BLOCK ASSEMBLY	2-1
2-2. FI-15 BOARD, DM-83 BOARD	2-1
2-3. REAR PANEL	2-2
2-4. POWER BLOCK, MA-338 BOARD (WITH S MECHANISM DECK)	2-2
2-5. S MECHANISM DECK	2-3
2-6. INTERNAL VIEWS	2-4
2-7. CIRCUIT BOARDS LOCATION	2-5
3. BLOCK DIAGRAMS	
3-1. OVERALL BLOCK DIAGRAM	3-1
3-2. VIDEO BLOCK DIAGRAM	3-3
3-3. SERVO/SYSTEM CONTROL/TUNER BLOCK DIAGRAM	3-5
3-4. AUDIO BLOCK DIAGRAM	3-7
3-5. POWER BLOCK DIAGRAM	3-9
4. PRINTED WIRING BOARDS AND SCHEMATIC DIAGRAMS	
4-1. FRAM SCHEMATIC DIAGRAM	4-3
4-2. PRINTED WIRING BOARDS AND SCHEMATIC DIAGRAMS	4-5
• MA-338 (VIDEO, AUDIO, SERVO/SYSTEM CONTROL, TUNER) PRINTED WIRING BOARD	4-5
• MA-338 (1/9) (REC/PB) SCHEMATIC DIAGRAM	4-7
• MA-338 (2/9) (VIDEO/AUDIO) SCHEMATIC DIAGRAM	4-9
• MA-338 (3/9) (AUDIO) SCHEMATIC DIAGRAM	4-11
• MA-338 (4/9) (SERVO/SYSTEM CONTROL) SCHEMATIC DIAGRAM	4-13
• MA-338 (5/9) (DISPLAY) SCHEMATIC DIAGRAM	4-15
• MA-338 (6/9) (INPUT/OUTPUT) SCHEMATIC DIAGRAM	4-17
• MA-338 (7/9) (TUNER) SCHEMATIC DIAGRAM	4-19
• MA-338 (8/9) (POWER SUPPLY) SCHEMATIC DIAGRAM	4-21
• MA-338 (9/9) (SECAM VIDEO PROCESSOR) SCHEMATIC DIAGRAM	4-23
• FI-15 (LINE-2 IN) PRINTED WIRING BOARD AND SCHEMATIC DIAGRAM	4-25
• DS-83 (DUAL SHATTLE) PRINTED WIRING BOARD AND SCHEMATIC DIAGRAM	4-26
• POWER BLOCK ETXNY165E1D (SWITCHING REGURATOR) PRINTED WIRING BOARD AND SCHEMATIC DIAGRAM	4-27
5. INTERFACE, IC PIN FUNCTION DESCRIPTION	
5-1. SYSTEM CONTROL — VIDEO/RP BLOCK INTERFACE (MA-338 BOARD IC162)	5-1
5-2. SYSTEM CONTROL — SERVO PERIPHERAL CIRCUIT INTERFACE (MA-338 BOARD IC162)	5-1
5-3. SYSTEM CONTROL — MECHANISM BLOCK INTERFACE (MA-338 BOARD IC162)	5-2
5-4. SYSTEM CONTROL — SYSTEM CONTROL PERIPHERAL CIRCUITE INTERFASE (MA-338 BOARD IC162)	5-2
5-5. SYSTEM CONTROL — AUDIO BLOCK INTERFACE (MA-338 BOARD IC162)	5-2
5-6. SERVO/SYSTEM CONTROL MICROPROCESSOR PIN FUNCTIONS (MA-338 BOARD IC162)	5-3
5-7. MODE CONTROL PIN FUNCTIONS (MA-338 BOARD IC420)	5-5
6. ADJUSTMENTS	
6-1. MECHANICAL ADJUSTMENTS	6-1
6-2. ELECTRICAL ADJUSTMENTS	6-1
2-1. PREPARATION BEFORE ADJUSTMENT	6-1
2-1-1. Equipment Required	6-1
2-1-2. Equipment Connection	6-1
2-1-3. Set-up of Adjustment	6-1
2-1-4. Alignment Tape	6-1
2-1-5. Input/Output Levels and Impedance	6-2
2-1-6. Adjustment Sequence	6-2
2-2. POWER SUPPLY CHECK	6-2
2-2-1. Output Voltage Check (MA-338 Board)	6-2
2-3. SERVO SYSTEM CHECK	6-3
2-3-1. RF Switching Position Adjustment (MA-338 Board)	6-3
2-4. AUDIO SYSTEM ADJUSTMENT	6-3
2-4-1. Normal Audio System Adjustment	6-3
2-4-2. ACE Head Adjustment	6-3
2-4-3. E-E Output Level Check	6-3
2-4-4. Frequency Response Check	6-3
2-5. ADJUSTING PARTS LOCATION DIAGRAM	6-4
7. REPAIR PARTS LIST	
7-1. EXPLODED VIEWS	7-1
7-1-1. FRONT PANEL AND UPPER CASE SECTION	7-1
7-1-2. CHASSIS SECTION	7-2
7-1-3. MECHANISM DECK SECTION-1	7-3
7-1-4. MECHANISM DECK SECTION-2	7-4
7-1-5. MECHANISM DECK SECTION-3	7-5
7-2. ELECTRICAL PARTS LIST	7-6

SERVICE NOTE

1. ERROR CODE INDICATION

- Error codes are indicated using the lower 5 digits in the fluorescent display tube.
“At this time, Colon “:” between character is not indicated.”

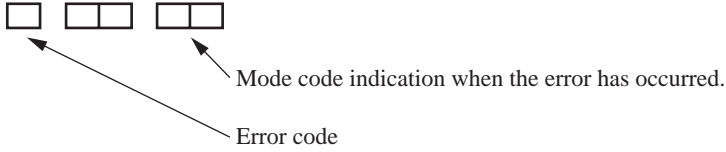

ERROR CODE

0	No error
1	Cam encoder error Loading direction
2	Cam encoder error Unloading direction
3	T reel error
4	S reel error
5	Capstan error
6	Drum error
7	Error on initializing
8	Cassette loading error
9	Reserve

MODE CODE

0	Power-on eject	10	FWD x1	20	REW play
1	Power-on initial	11	FWD x2	21	Cas. loading
2	Power-off eject	12	CUE	22	Tape loading
3	Power-off stop	13	PB-pause	23	Power-off loading
4	FF	14	RVS-pause	24	Mecha. error (Power on)
5	REW	15	RVS x1	25	Power-on eject initial
6	REC	16	RVS x2	26	Power-off eject initial
7	REC- pause	17	REV	27	APC REC
8	Power-on stop	18	Power-off initial	28	Cas. loading
9	PB	19	Mecha. error (Power off)		(No auto PB check)

SECTION 1
GENERAL

This section is extracted from instruction manual.

Getting Started

Step 1

Unpacking

Check that you have received the following items with the VCR:

- Remote commander

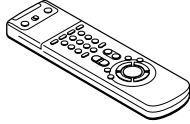

- Aerial cable



- R6 (size AA) batteries



Checking your model name

The instructions in this manual are for the 2 models: SLV-SE30UX and SE45UX. Check your model number by looking at the rear panel of your VCR. The SLV-SE30UX is the model used for illustration purposes. Any difference in operation is clearly indicated in the text, for example, "SLV-SE45UX only."

4 Getting Started

Step 2

Setting up the remote commander

Inserting the batteries

Insert two R6 (size AA) batteries by matching the + and - on the batteries to the diagram inside the battery compartment.

Insert the negative (-) end first, then push in and down until the positive (+) end clicks into position.

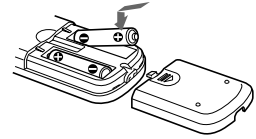

Using the remote commander

You can use this remote commander to operate this VCR and a Sony TV. Buttons on the remote commander marked with a dot (•) can be used to operate your Sony TV. If the TV does not have the symbol near the remote sensor, this remote commander will not operate the TV.

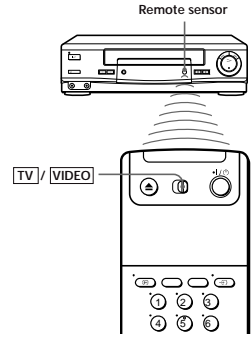

To operate	Set [TV] / [VIDEO] to
the VCR	[VIDEO] and point at the remote sensor on the VCR
a Sony TV	[TV] and point at the remote sensor on the TV

continued

Getting Started 5

Step 2 : Setting up the remote commander (continued)

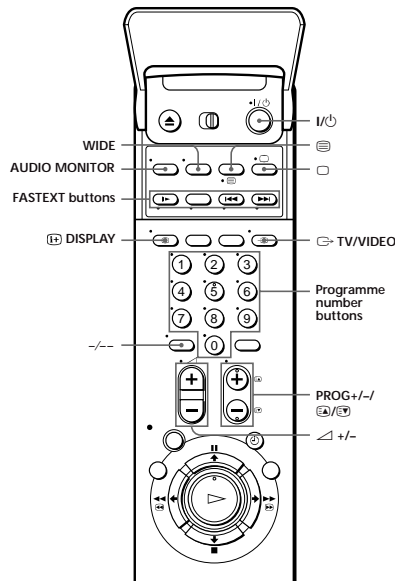

TV control buttons

To	Press
Turn the TV into standby mode	I/⏻
Select an input source of the TV either from aerial in or from line in	TV / VIDEO
Select the programme position of the TV	Programme number buttons, +/-, PROG +/-
Adjust the volume of the TV	△ +/-

6 Getting Started

To	Press
Switch to TV (Teletext off)	□ (TV)
Switch to Teletext	⊞ (Teletext)
Select the sound	AUDIO MONITOR
Use FASTEXT	FASTEXT buttons
Call up on-screen display	⊞ DISPLAY
Change the Teletext page	⊞ / ⊞

Switch to /from wide mode of a Sony wide TV (For WIDE other manufacture's wide TV, see "Controlling other TVs with the remote commander" below.)

Notes

- With normal use, the batteries should last about three to six months.
- If you do not use the remote commander for an extended period of time, remove the batteries to avoid possible damage from battery leakage.
- Do not use a new battery with an old one together.
- Do not use different types of batteries together.
- Some buttons may not work with certain Sony TVs.

Controlling other TVs with the remote commander

The remote commander is preprogrammed to control non-Sony TVs. If your TV is listed in the table below, set the appropriate manufacturer's code number.

- 1 Set **[TV]** / **[VIDEO]** at the top of the remote commander to **[TV]**.
 - 2 Hold down I/⏻, and enter your TV's code number(s) using the programme number buttons. Then release I/⏻.
- Now you can use the following TV control buttons to control your TV: I/⏻, TV / VIDEO, programme number buttons, +/- (ten's digit), PROG +/-, +/-, (TV), (Teletext), FASTEXT buttons, WIDE*, MENU*, / / / *, and OK*.

* These buttons may not work with all TVs.

Tip

- When you set your TV's code number correctly while the TV is turned on, the TV turns off automatically.

continued

Getting Started 7

Step 2 : Setting up the remote commander (continued)

Code numbers of controllable TVs

If more than one code number is listed, try entering them one at a time until you find the one that works with your TV.

To make wide mode settings, see the footnotes below this table for the applicable code numbers.

Manufacturer	Code number	Manufacturer	Code number
Sony	01 ^{*1} , 02	Panasonic	17 ^{*1} , 49
Akai	68	Philips	06 ^{*1} , 07 ^{*1} , 08 ^{*1}
Ferguson	52	Saba	12, 13
Grundig	10 ^{*1} , 11 ^{*1}	Samsung	22, 23
Hitachi	24	Sanyo	25
JVC	33	Sharp	29
Loewe	45	Telefunken	36
Mivar	09, 70	Thomson	43 ^{*2}
NEC	66	Toshiba	38
Nokia	15, 16, 69 ^{*3}		

^{*1} Press WIDE to switch the wide picture mode on or off.

^{*2} Press WIDE, then press Δ +/- to select the wide picture mode you want.

^{*3} Press WIDE. The menu appears on the TV screen. Then, press $\uparrow/\downarrow/\leftarrow/\rightarrow$ to select the wide picture you want and press OK.

Notes

- If the TV uses a different remote control system from the one programmed to work with the VCR, you cannot control your TV with the remote commander.
- If you enter a new code number, the code number previously entered will be erased.
- When you replace the batteries of the remote commander, the code number may change. Set the appropriate code number every time you replace the batteries.

Step 3

Connecting the VCR

If your TV has a EURO-AV connector, see page 10.

If your TV does not have a EURO-AV (Scart) connector

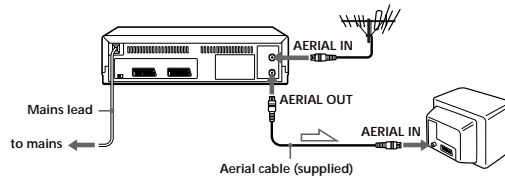

Signal flow

- 1 Disconnect the aerial cable from your TV and connect it to AERIAL IN on the rear panel of the VCR.
- 2 Connect AERIAL OUT of the VCR and the aerial input of your TV using the supplied aerial cable.
- 3 Connect the mains lead to the mains. If the mains plug does not fit in the mains, use the supplied plug adaptor.

Note

- When you connect the VCR and your TV only with an aerial cable, you have to set RF MODULATOR in the OPTIONS-2 menu to ON (initial setting) (see page 63).

continued

Step 3 : Connecting the VCR (continued)

If your TV has a EURO-AV (Scart) connector

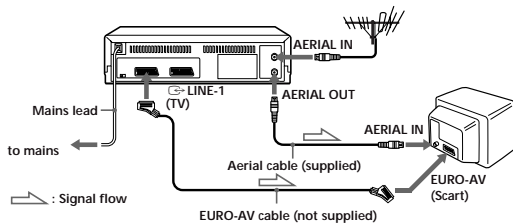

- 1 Disconnect the aerial cable from your TV and connect it to AERIAL IN on the rear panel of the VCR.
- 2 Connect AERIAL OUT of the VCR and the aerial input of your TV using the supplied aerial cable.

- 3 Connect LINE-1 (TV) on the VCR and the EURO-AV (Scart) connector on the TV with the optional EURO-AV cable. This connection improves picture and sound quality. Whenever you want to watch the VCR picture, press \square TV/VIDEO to display the VIDEO indicator in the display window.
- 4 Connect the mains lead to the mains. If the mains plug does not fit in the mains, use the supplied plug adaptor.

Note

- If the TV is connected to the LINE-1 (TV) connector, setting the RF MODULATOR in the OPTIONS-2 menu to OFF is recommended. In the OFF position, only the signal from the aerial is output through the AERIAL OUT connector (see page 63). You do not have to tune your TV to the VCR. Skip "Tuning your TV to the VCR" on page 14.

About the SMARTLINK features

If the connected TV complies with SMARTLINK MEGALOGIC^{*1}, EASYLINK^{*2}, Q-Link^{*3}, or EURO VIEW LINK^{*4}, you can use the SMARTLINK function after you complete the steps on the previous page (the SMARTLINK indicator appears in the VCR's display window when you turn on the TV). You can enjoy the following SMARTLINK features.

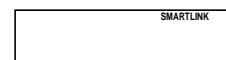

- **Preset Download**
You can download your TV tuner preset data to this VCR and tune the VCR according to that data in Auto Set Up. This greatly simplifies the Auto Set Up procedure. Be careful, not to disconnect the cables or exit the Auto Set Up function during the procedure.
See "Setting up the VCR with the Auto Set Up function" on page 13.

continued

Step 3 : Connecting the VCR (continued)

- **TV Direct Rec**
You can easily record what you are watching on the TV (other than tapes being played on this VCR). For details, see "Recording what you are watching on the TV (TV Direct Rec)" on page 41.
 - **One Touch Play**
With One Touch Play, you can start playback automatically without turning on the TV. For details, see "Starting playback automatically with one button (One Touch Play)" on page 36.
 - **One Touch Menu**
You can turn on the VCR and TV, set the TV to the video channel, and display the VCR's on-screen display automatically by pressing MENU on the remote commander.
 - **One Touch Timer**
You can turn on the VCR and TV, set the TV to the video channel, and display the timer recording menu (the TIMER METHOD menu, the TIMER menu, or the VIDEO PLUS+ menu) automatically by pressing  TIMER on the remote commander.
- You can set which timer recording menu is displayed using TIMER OPTIONS in the OPTIONS-2 menu (see page 63).

*1 "MEGALOGIC" is a registered trademark of Grundig Corporation.
 *2 "EASYLENK" is a trademark of Philips Corporation.
 *3 "Q-Link" is a trademark of Panasonic Corporation.
 *4 "EURO VIEW LINK" is a trademark of Toshiba Corporation.

Note
 • Not all the TVs respond to the functions above.

Step 4

Setting up the VCR with the Auto Set Up function

Before using the VCR for the first time, set up the VCR using the Auto Set Up function. With this function, you can set TV channels, guide channels for the VIDEO Plus+ system, the RF channel, and VCR clock automatically.

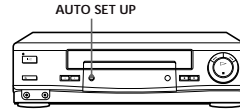

AUTO SET UP



Hold down AUTO SET UP on the VCR for more than three seconds. The VCR automatically turns on and VCR starts searching for all of the receivable channels and presets them in the appropriate order for your local area.



If you use the SMARTLINK connection, the Preset Download function starts and the SMARTLINK indicator flashes in the display window during download.

After the search is complete, the current time appears in the display window for any stations that transmit a time signal. If the time does not appear, set the clock manually. See page 27.

To cancel the Auto Set Up function

Press AUTO SET UP.

Note

- Do not cancel the Auto Set Up function. If you do, repeat the step above.

Step 5

Tuning your TV to the VCR

If you have connected the VCR to your TV using the EURO-AV cable, skip this step.

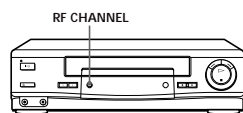

1



Press RF CHANNEL on the VCR. The factory-preset RF channel appears in the display window. The VCR signal is output through this channel to the TV.

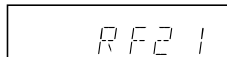

2

Turn on your TV and select a programme position for the VCR picture. This programme position will now be referred to as the video channel.

3

Tune the TV to the same channel as that shown in the display window so that the picture on the right appears clearly on the TV screen.

Refer to your TV manual for tuning instructions.

If the picture does not appear clearly, see "To obtain a clear picture from the VCR" below.



4



Press RF CHANNEL.

You have now tuned your TV to the VCR. Whenever you want to play a tape, set the TV to the video channel.

To check to see if the TV tuning is correct

Set the TV to the video channel and press PROGRAM +/- on the VCR. If the TV screen changes to a different programme each time you press PROGRAM +/-, the TV tuning is correct.

To obtain a clear picture from the VCR

If the screen does not appear clearly in step 3 above, press PROGRAM +/-, so that another RF channel appears. Then tune the TV to the new RF channel until a clear picture appears.

Selecting a language

If you prefer an on-screen language other than English, use the on-screen display to select another language.

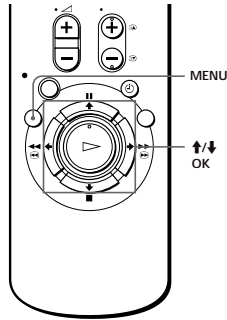

Before you start...

- Turn on the VCR and the TV.
- Set the TV to the video channel.



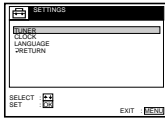

- 

Press MENU, then press \uparrow/\downarrow to highlight SETTINGS and press OK.

- 

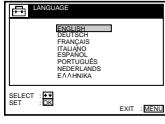
Press \uparrow/\downarrow to highlight LANGUAGE, then press OK.

- 

Press \uparrow/\downarrow to highlight the desired language, then press OK.

- 

Press MENU to exit the menu.

Tip

- If you want to return to the previous menu, highlight RETURN and press OK.

Note

- The menu disappears automatically if you don't proceed for more than a few minutes.

Presetting channels

If some channels could not be preset using the Auto Set Up function, you can preset them manually.

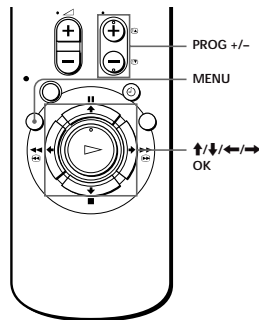

Before you start...

- Turn on the VCR and the TV.
- Set the TV to the video channel.



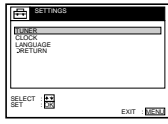

- 

Press MENU, then press \uparrow/\downarrow to highlight SETTINGS and press OK.

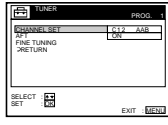

- 

Press \uparrow/\downarrow to highlight TUNER, then press OK.

- 

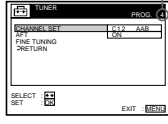

Press PROG +/- to select the programme position.

Selected programme position



- 

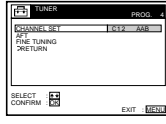

Press \uparrow/\downarrow to highlight CHANNEL SET, then press OK.

- 

Press \uparrow/\downarrow repeatedly until the channel you want is displayed. The channels appear in the following order:

 - UHF B21 - B69

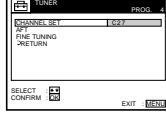
If you know the number of the channel you want, press the programme number buttons. For example, for channel 5, first press "0" and then press "5."

- To allocate another channel to another programme position, repeat steps 3 and 5.
- 

Press MENU to exit the menu.

Disabling unwanted programme positions

After presetting channels, you can disable unused programme positions. The disabled positions will be skipped later when you press the PROG +/- buttons.

- 1 In step 5 above, press programme number button "0" twice to display the number "00" beside CHANNEL SET.
- 2 Press MENU to exit the menu.

continued

Presetting channels (continued)

If the picture is not clear

Normally, the Auto Fine Tuning (AFT) function automatically tunes in channels clearly. If, however, the picture is not clear, you may also use the manual tuning function.

- 1 Press PROG +/- or the programme number buttons to select the programme position for which you cannot obtain a clear picture.
- 2 Press MENU, then select SETTINGS and press OK.
- 3 Select TUNER, then press OK.
- 4 Select FINE TUNING, then press OK.

The fine tuning meter appears.

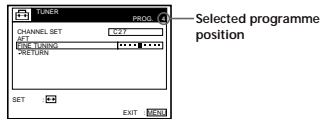

- 5 Press ←/→ to get a clearer picture, then press MENU to exit the menu.

Note that the AFT (Auto Fine Tuning) setting switches to OFF.

Tip

- If you want to return to the previous menu, highlight RETURN and press OK.

Note

- The menu disappears automatically if you don't proceed for more than a few minutes.

**Changing/
disabling
programme
positions**

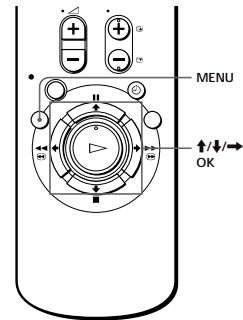

After setting the channels, you can change the programme positions and the station names as you like. If any programme positions are unused or contain unwanted channels, you can disable them. If the station names are not displayed, you can enter them manually (see page 23).

Changing programme positions

Before you start...

- Turn on the VCR and the TV.
- Set the TV to the video channel.

- 1 Press MENU, then press ↑/↓ to highlight LISTS and press OK.

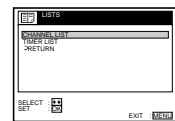

- 2 Press ↑/↓ to highlight CHANNEL LIST, then press OK.

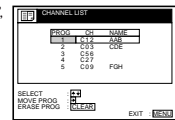

continued

Changing/disabling programme positions (continued)

- 3 Press ↑/↓ to highlight the row on which you want to change the programme position, then press →. To display other pages for programme positions 6 to 60, press ↑/↓ repeatedly.

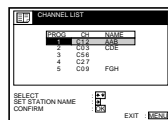

- 4 Press ↑/↓ until the selected channel row moves to the desired programme position. The selected channel is inserted at the new programme position and the intermediate channels are displaced to fill the gap.

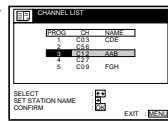

- 5 Press OK to confirm the setting.



- 6 To change the programme position of another station, repeat steps 3 to 5.

- 7 Press MENU to exit the menu.



Tip

- If you want to return to the previous menu, highlight RETURN and press OK.

Note

- The menu disappears automatically if you don't proceed for more than a few minutes.

Changing the station names

You can change the station names (up to 5 characters).

Before you start...

- Turn on the VCR and the TV.
- Set the TV to the video channel.

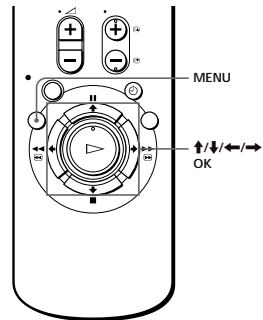

- 1 Press MENU, then press ↑/↓ to highlight LISTS and press OK.

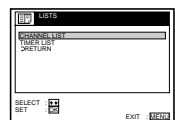

- 2 Press ↑/↓ to highlight CHANNEL LIST, then press OK.

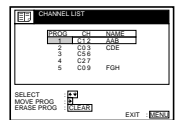

- 3 Press ↑/↓ to highlight the row on which you want to change the station name, then press →.

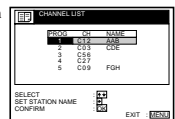

To display other pages for programme positions 6 to 60, press ↑/↓ repeatedly.

continued

Changing/disabling programme positions (continued)

4 Press **→**.

5 Enter the station name.

1 Press **↑/↓** to select a character. Each time you press **↑**, the character changes as shown below.

A → B → ... → Z → a → b → ... → z
 → 0 → 1 → ... → 9 → (symbols)
 → (blank space) → A

2 Press **→** to set the next character. The next space is highlighted. To correct a character, press **←/→** until the character you want to correct is highlighted, then reset it. You can set up to 11 characters for the station name.

6 Press OK to confirm the new name.

7 Press MENU to exit the menu.

Tip

- If you want to return to the previous menu, highlight RETURN and press OK.

Note

- The menu disappears automatically if you don't proceed for more than a few minutes.

Disabling unwanted programme positions

After presetting channels, you can disable unused programme positions. The disabled positions will be skipped later when you press the PROG +/− buttons.

Before you start...

- Turn on the VCR and the TV.
- Set the TV to the video channel.

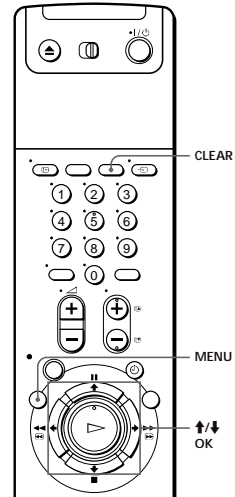

1 Press MENU, then press **↑/↓** to highlight LISTS, and press OK.

continued

Changing/disabling programme positions (continued)

2 Press **↑/↓** to highlight CHANNEL LIST, then press OK.

3 Press **↑/↓** to highlight the row on which you want to disable.

4 Press CLEAR. The selected row will be cleared as shown on the right.

5 Repeat steps 3 and 4 for any other programme positions you want to disable.

6 Press MENU to exit the menu.

Tip

- If you want to return to the previous menu, highlight RETURN and press OK.

Notes

- The menu disappears automatically if you don't proceed for more than a few minutes.
- Be sure to select the programme position you want to disable correctly. If you disable a programme position by mistake, you need to reset that channel manually.

Setting the clock

You must set the time and date on the VCR to use the timer recording features properly. If the VCR clock was not set in the Auto Set Up procedure, you need to set it manually.

The Auto Clock Set function works only if a station in your area is broadcasting a time signal. If the Auto Set Up function did not set the clock correctly for your local area, try another station for the Auto Clock Set function.

Setting the clock manually

Before you start...

- Turn on the VCR and the TV.
- Set the TV to the video channel.

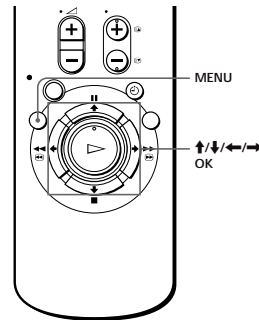





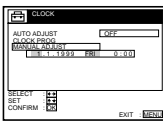

1 Press MENU, then press **↑/↓** to highlight SETTINGS and press OK.

2 Press **↑/↓** to highlight CLOCK, then press OK.

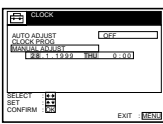
continued

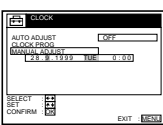
Setting the clock (continued)

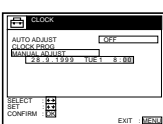
- 3  Press **↑/↓** to highlight MANUAL ADJUST, then press OK. 
- 4  Press **↑/↓** to set the date. 
- 5  Press **→** to highlight the month and set the month pressing **↑/↓**. 
- 6  Set the year, hour, and minutes in sequence, pressing **→** to highlight the item to be set, and press **↑/↓** to select the digits. The day of the week is set automatically. 

- 7  Press OK to start the clock. 

- 8  Press MENU to exit the menu.

Tips

- To change the digits during setting, press **←** to return to the item to be changed, and select the digits pressing **↑/↓**.
- If you want to return to the previous menu, highlight RETURN and press OK.

Note

- The menu disappears automatically if you don't proceed for more than a few minutes.





continued

Setting the clock (continued)

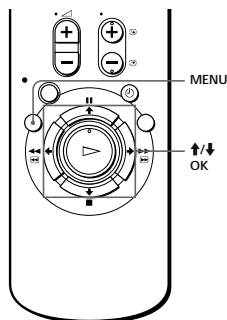
Changing the station for the Auto Clock Set function

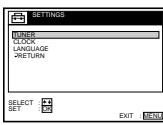
- Before you start...
- Turn on the VCR and the TV.
 - Set the TV to the video channel.

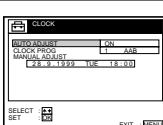

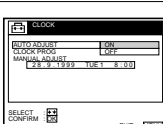
- 1  Press MENU, then press **↑/↓** to highlight SETTINGS and press OK. 
- 2  Press **↑/↓** to highlight CLOCK, then press OK. AUTO ADJUST is highlighted. 
- 3  Press OK. 

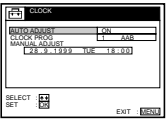
- 4  Press **↑/↓** to highlight ON, then press OK. 

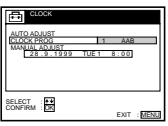
- 5  Press **↓** to highlight CLOCK PROG, then press OK. 

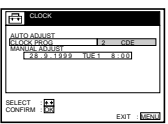
- 6  Press **↑/↓** repeatedly until the programme position of the station that carries the time signal appears. If the VCR does not receive the time signal from any station, AUTO ADJUST returns to OFF automatically. 

- 7  Press MENU to exit the menu.

Tips

- If you set AUTO ADJUST to ON, the Auto Clock Set function is activated whenever the VCR is turned off. The time is adjusted automatically by making reference to the time signal from the station whose programme position is displayed in the "CLOCK PROG" row.
- If you do not need the Auto Clock Set, select OFF.
- If you want to return to the previous menu, highlight RETURN and press OK.

Note

- The menu disappears automatically if you don't proceed for more than a few minutes.

Setting your personal code

For identification, you can enter a personal code into the VCR. Once you enter your personal code, you can confirm it any time but can never change it. Please make a note of the code to quote to the police if your VCR is stolen.

Before you start...

- Turn on your TV and set it to the video channel.
- If there is a tape in the VCR, remove it.
- Turn off the VCR.

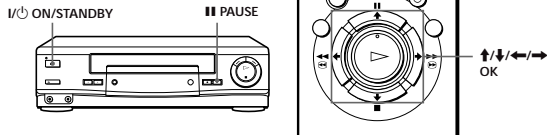

- Hold down **PAUSE** and **I/ON/STANDBY** on the VCR simultaneously for more than three seconds.

- Enter your personal code.

1 Press **↑/↓** to select a character. Each time you press **↑**, the character changes as shown below.
A → B → ... → Z → 0 → 1 → ... → 9 → (blank space) → - (hyphen) → A
- Press **→** to set the next character. The next space is highlighted. To correct a character, press **←/→** until the character you want to correct is highlighted, then reset it. You can set up to 11 characters for your personal code.
- Press **OK**. A confirmation screen appears.
- If the displayed personal code is correct, press **OK**. If the displayed personal code is wrong, press **CLEAR** and continue from step 2.

To confirm your personal code

While the VCR is turned off and there is no tape in the VCR, hold down **PAUSE** and **I/ON/STANDBY** on the VCR simultaneously for more than three seconds. The entered personal code appears on the TV screen. Press any button to enter normal viewing mode.

Note

- The menu disappears automatically if you don't proceed for more than a few minutes.

Basic Operations

Playing a tape

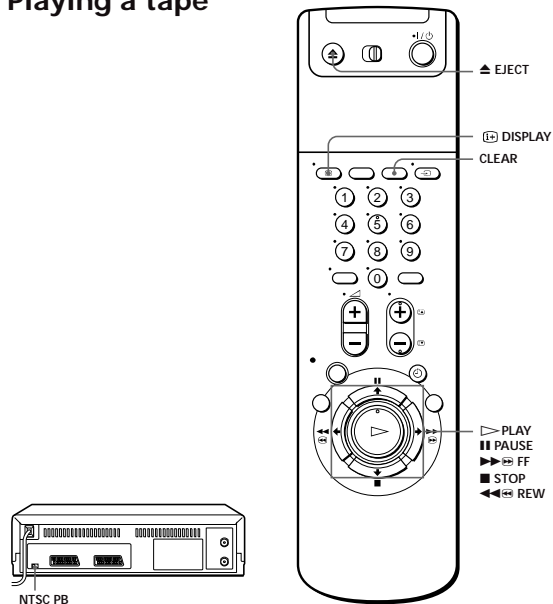

- Turn on your TV and set it to the video channel.
- Insert a tape. The VCR turns on and starts playing automatically if you insert a tape with its safety tab removed.

- Press **▶ PLAY**. When the tape reaches the end, it will rewind automatically.

Additional tasks

To	Press
Stop play	■ STOP
Pause play	▬ PAUSE
Resume play after pause	▬ PAUSE or ▶ PLAY
Fast-forward the tape	▶▶ FF during stop
Rewind the tape	◀◀ REW during stop
Eject the tape	▲ EJECT

To play an NTSC-recorded tape

Set NTSC PB at the rear of the VCR according to the colour system of your TV.

When your TV is	Set NTSC PB to
PAL only	ON PAL TV
PAL and NTSC	NTSC 4.43

To use the time counter

At the point on the tape that you want to find later, press **CLEAR**. The counter in the display window resets to "0:00:00." Search for the point afterwards by referring to the counter.

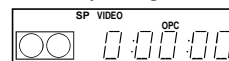

To display the counter on the TV screen, press **Ⓢ DISPLAY**.

continued

Playing a tape (continued)

Notes

- The counter resets to "0:00:00" whenever a tape is reinserted.
- The counter stops counting when it comes to a portion with no recording.
- The time counter does not appear on the TV screen when using an NTSC-recorded tape.
- Depending on your TV, the following may occur while playing an NTSC-recorded tape:
 - The picture becomes black and white.
 - The picture shakes.
 - No picture appears on the TV screen.
 - Black streaks appear horizontally on the TV screen.
 - The colour density increases or decreases.
- While setting the menu on the TV screen, buttons for playback on the remote commander do not function.

Starting playback automatically with one button (One Touch Play)

If you use the SMARTLINK connection, you can turn on the VCR and the TV, set the TV to the video channel, and start playback automatically with one button.

- Insert a tape.

The VCR automatically turns on.

If you insert a tape with its safety tab removed, the TV turns on and switches to the video channel. Playback starts automatically.
- Press \triangleright PLAY.

The TV turns on and switches to the video channel automatically. Playback starts.

Tip

- When there already is a tape in the VCR, the VCR and the TV turn on, the TV is set to the video channel, and playback starts automatically in one sequence when you press \triangleright PLAY.

Note

- When you use the One Touch Play function, leave the TV on or in the standby mode.

Recording TV programmes

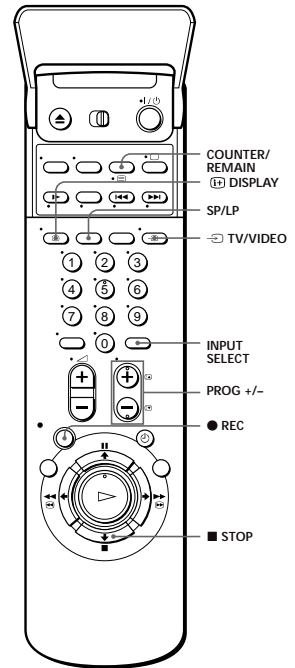

- Turn on your TV and set it to the video channel.
- Insert a tape with its safety tab in place.

continued

Recording TV programmes (continued)

- Press INPUT SELECT until a programme position number appears in the display window.

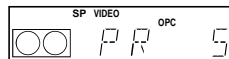

- Press PROG +/- to select the programme position you want to record.

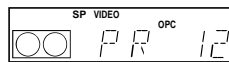

- Press SP/LP to select the tape speed, SP or LP. LP (Long Play) provides recording time twice as long as SP, however, SP (Standard Play) produces better picture and audio quality.



- Press REC to start recording. The recording indicator lights up red in the display window.

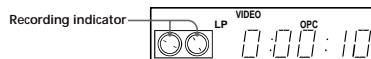

To stop recording
Press ■ STOP.

To check the remaining time

Press DISP DISPLAY. With the display on, press COUNTER/REMAIN to check the remaining time. Each time you press COUNTER/REMAIN, the time counter and the remaining time appear alternately. The remaining time with the C indicator also appears in the display window.

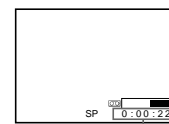

Time counter

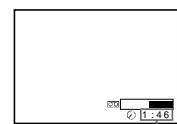

Remaining time

To correctly check the remaining time of the tape, set TAPE LENGTH in the OPTIONS-1 menu according to the tape type you use (see page 63).

To watch another TV programme while recording

- Press TV/VIDEO to turn off the VIDEO indicator in the display window.
- Select another programme position on the TV.

To save a recording

To prevent accidental erasure, break off the safety tab as illustrated. To record on a tape again, cover the tab hole with adhesive tape.



Safety tab

continued

Recording TV programmes (continued)

Tips

- To select a programme position, you can use the programme number buttons on the remote commander. For two-digit numbers, press the --- (ten's digit) button followed by the programme number buttons.
- You can select a video source from the LINE-1 (TV) connector, the LINE-2 IN jacks, or the LINE-3 IN (Scart) connector also using the INPUT SELECT button.
- The display appears on the TV screen indicating information about the tape, but the information won't be recorded on the tape.
- If you don't want to watch TV while recording, you can turn off the TV.

Notes

- The display does not appear during still (pause) mode or slow-motion playback.
- The display will not appear while playing an NTSC-recorded tape.
- If a tape has portions recorded in both PAL and NTSC systems, the time counter reading will not be correct. This discrepancy is due to the difference between the counting cycles of the two video systems.
- When you insert a non-standard commercially available tape, the remaining time may not be correct.
- The remaining time is intended for rough measurement only.
- About 30 seconds after the tape begins playback, the tape remaining time will be displayed.

Recording what you are watching on the TV (TV Direct Rec)

If you use the SMARTLINK connection, you can easily record what you are watching on the TV (other than tapes being played on the VCR).

- 1 Insert a tape with its safety tab in place.
- 2 Press \bullet REC while you are watching a TV programme or external source.

The VCR automatically turns on, then the TV indicator lights up and the VCR starts recording what you are watching on the TV.

Tips

- The TV indicator appears in the display window after you press \bullet REC in some situations such as:
 - when you are watching a source connected to the TV's line input, or
 - when the TV tuner preset data for the programme position is different from the data in the VCR tuner preset.
- If there is a tape with its safety tab in place in the VCR, the VCR automatically turns on and starts recording what you are watching on the TV when you press \bullet REC.
- You can turn the TV Direct Rec function ON and OFF in the OPTIONS-2 menu (see page 63).

Notes

- You cannot record what you are watching using this method when the VCR is in the following modes; pause, timer standby, tuner preset, Auto Set Up, and recording.
- When the TV indicator is lit in the display window, do not turn off the TV nor change the TV programme position. When the TV indicator is not lit, the VCR continues recording the programme even if you change the TV programme position on the TV.

Recording TV programmes using the VIDEO Plus+ system

The VIDEO Plus+ system is the feature that simplifies programming the VCR to make timer recording. Just enter the PlusCode number listed in the TV programme guide. The date, times, and programme position of that programme are set automatically. You can preset up to eight programmes at a time.

Before you start...

- Check that the VCR clock is set to the correct time and date.
- Insert a tape with its safety tab in place. Make sure the tape is longer than the total recording time.
- Turn on your TV and set it to the video channel.
- Set TIMER OPTIONS to VIDEO PLUS+ or VARIABLE in the OPTIONS-2 menu (see page 63).

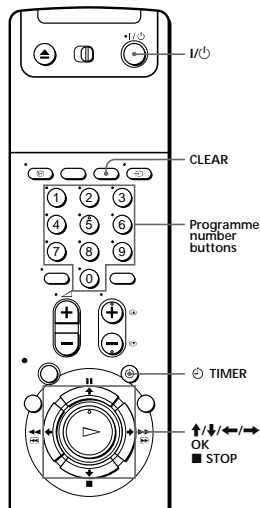

- 2 Press the programme number buttons to enter the PlusCode number.



If you make a mistake, press CLEAR and re-enter the correct number.



- 3 Press OK.



The date, start and stop times, programme position, tape speed, and VPS/PDC setting appear on the TV screen.

- If "--" appears in the "PROG." (programme) column (this may happen for local broadcasts), you have to set the appropriate programme position manually.

Press \uparrow/\downarrow to select the desired programme position.

To record from a source connected to the LINE-1 (TV) connector, the LINE-2 IN jacks, or the LINE-3 (Scart) connector, press INPUT SELECT to display "L1", "L2", or "L3."

You will only have to do this operation once for the referred channel. The VCR will then store your setting.



If the information is incorrect, press CLEAR to cancel the setting.

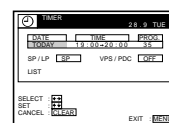

continued

- 1 Press \odot TIMER.



- When you set TIMER OPTIONS to VARIABLE
- The TIMER METHOD menu appears on the TV screen. Press \uparrow/\downarrow to select VIDEO PLUS+, then press OK.

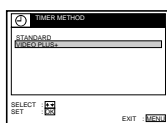

- When you set TIMER OPTIONS to VIDEO PLUS+
- The VIDEO PLUS+ menu appears on the TV screen.

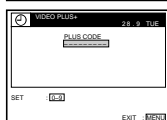

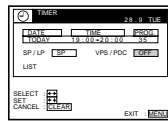

Recording TV programmes using the VIDEO Plus+ system (continued)

- 4**  If you want to change the date, tape speed, and the VPS/PDC function setting:
- 1 Press \leftarrow/\rightarrow to highlight the item you want to change.
 - 2 Press \uparrow/\downarrow to reset it.
- To record the same programme every day or the same day every week, see "Daily/weekly recording" below.
 - To use the VPS/PDC function, set VPS/PDC to ON. For details of the VPS/PDC function, see "Timer recording with VPS/PDC signals" on page 45.



- 5**  Press MENU to exit the menu.

- 6**  Press I/⏻ to turn off the VCR. The  indicator appears in the display window and the VCR stands by for recording.

To stop recording

To stop the VCR while recording, press \blacksquare STOP.

Daily/weekly recording

In step 4 above, press \downarrow to select the recording pattern. Each time you press \downarrow , the indication changes as shown below. Press \uparrow to change the indication in reverse order.

TODAY \rightarrow SUN-SAT (Sunday to Saturday) \rightarrow MON-SAT (Monday to Saturday)
 \rightarrow MON-FRI (Monday to Friday) \rightarrow SAT (every Saturday)
 \rightarrow MON (every Monday) \rightarrow SUN (every Sunday) \rightarrow 1 month later
 \rightarrow (dates count down) \rightarrow TOMORROW \rightarrow TODAY

Timer recording with VPS/PDC signals

Some broadcast systems transmit VPS (Video Programme System) or PDC (Programme Delivery Control) signals with their TV programmes. These signals ensure that your timer recordings are made regardless of broadcast delays, early starts, or broadcast interruptions (with the VPS or PDC indicator in the display window lit).

To use the VPS/PDC function, set VPS/PDC to ON in step 4 above. You can also use the VPS/PDC function for a source connected to the LINE-1 (TV) connector, the LINE-2 IN jacks, and the LINE-3 (Scart) connector.

To record satellite broadcasts

If you connect the satellite tuner and the VCR, you can record satellite programmes.

- 1 Turn on the satellite tuner.
- 2 On the satellite tuner, select the satellite programme for which you want to make a timer setting.
- 3 Keep the satellite tuner turned on until the VCR finishes recording the satellite programme for which you have made a timer setting.

To use the VCR after setting the timer

To use the VCR before a timer recording begins, just press I/⏻. The  indicator turns off and the VCR switches on. Remember to press I/⏻ to reset the VCR after using the VCR.

You can also do the following tasks while the VCR is recording:

- Reset the counter.
- Display tape information on the TV screen.
- Check the timer settings.
- Watch another TV programme.

continued

Recording TV programmes using the VIDEO Plus+ system (continued)

Tips

- To set the programme position with a two digit number, press -/-- (ten's digit) button followed by the programme number button.
- To set the programme position, you can also use the PROG +/- or programme number buttons.
- To set the tape speed, you can also use the SP/LP button.
- When you are recording a programme in the SP mode and the remaining tape becomes shorter than the recording time, the tape speed is automatically changed to the LP mode. Note that some interference will appear on the picture at the point the tape speed is changed. If you want to keep the same tape speed, set AUTO LONG PLAY to OFF in the OPTIONS-1 menu (page 63).
- To check, change, or clear the programme setting, press \leftarrow/\rightarrow to choose LIST, then press OK after step 4. For details, see step 3 in "Checking/changing/cancelling timer settings" (page 54).

Notes

- If the VPS/PDC signal is too weak or the broadcasting station failed to transmit VPS/PDC signals, the VCR will start recording at the set time without using the VPS/PDC function.
- The  indicator flashes in the display window when you press I/⏻ with no tape inserted.
- When you set TIMER OPTIONS to STANDARD in the OPTIONS-2 menu, the VIDEO PLUS+ menu does not appear on the TV screen. Select VIDEO PLUS+ or VARIABLE.



Setting the timer manually

If the VIDEO Plus+ system is not available in your area, follow the instructions below to set the timer to record programmes.

Before you start...

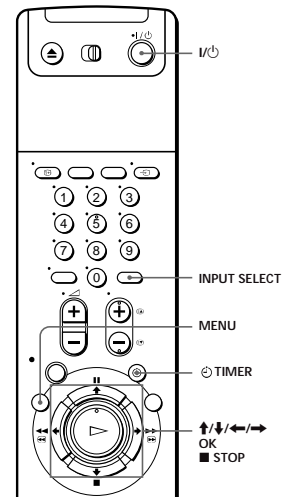
- Check that the VCR clock is set to the correct time and date.
- Insert a tape with its safety tab in place. Make sure the tape is longer than the total recording time.
- Turn on your TV and set it to the video channel.
- Set TIMER OPTIONS to STANDARD or VARIABLE in the OPTIONS-2 menu (see page 63).



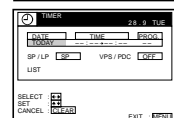
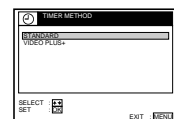

- 1**  Press  TIMER.
- When you set TIMER OPTIONS to VARIABLE
The TIMER METHOD menu appears on the TV screen. Press \uparrow/\downarrow to select STANDARD, then press OK.
 - When you set TIMER OPTIONS to STANDARD
The TIMER menu appears on the TV screen.



continued

Setting the timer manually (continued)

- 2  Set the date, start and stop times, programme position, tape speed, and VPS/PDC function:
 - 1 Press \rightarrow to highlight each item in turn.
 - 2 Press \uparrow/\downarrow to set each item.
 To correct a setting, press \leftarrow to return to that setting and reset.
 - To record the same programme every day or the same day every week, see "Daily/weekly recording" on page 49.
 - To use the VPS/PDC function, set VPS/PDC to ON. For details of the VPS/PDC function, see "Timer recording with VPS/PDC signals" on page 45.
 - To record from a source connected to the LINE-1 (TV) connector, the LINE-2 IN jacks, or the LINE-3 (Scart) connector, press INPUT SELECT to display "L1", "L2", or "L3" in the "PROG." position.
- 3  Press MENU to exit the menu.
- 4  Press I/O to turn off the VCR.

The \odot indicator appears in the display window and the VCR stands by for recording.

To record from a source, leave the connected equipment switched on.

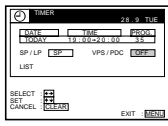

To stop recording
To stop the VCR while recording, press ■ STOP.

Daily/weekly recording

In step 2 above, press \downarrow to select the recording pattern. Each time you press \downarrow , the indication changes as shown below. Press \uparrow to change the indication in reverse order.

- TODAY \rightarrow SUN-SAT (Sunday to Saturday) \rightarrow MON-SAT (Monday to Saturday) \rightarrow MON-FRI (Monday to Friday) \rightarrow SAT (every Saturday)
- \rightarrow MON (every Monday) \rightarrow SUN (every Sunday) \rightarrow 1 month later
- \rightarrow (dates count down) \rightarrow TOMORROW \rightarrow TODAY

Tips

- To set the programme position, you can also use the PROG +/- or programme number buttons.
- To set the tape speed, you can also use the SP/LP button.
- When you are recording a programme in the SP mode and the remaining tape becomes shorter than the recording time, the tape speed is automatically changed to the LP mode. Note that some interference will appear on the picture at the point the tape speed is changed. If you want to keep the same tape speed, set AUTO LONG PLAY to OFF in the OPTIONS-1 menu (page 63).
- Even if you set TIMER OPTIONS to VIDEO PLUS+ in the OPTIONS-2 menu, you can set the timer manually. Press MENU to select TIMER, then go to step 2.

Notes

- When setting the timer with VPS/PDC signals, enter the start and stop times exactly as indicated in the TV programme guide, otherwise the VPS/PDC function won't work.
- If the VPS/PDC signal is too weak or the broadcasting station failed to transmit VPS/PDC signals, the VCR will start recording at the set time without using the VPS/PDC function.
- The \odot indicator flashes in the display window when you press I/O with no tape inserted.

Basic Operations

Additional Operations

Playing/searching at various speeds

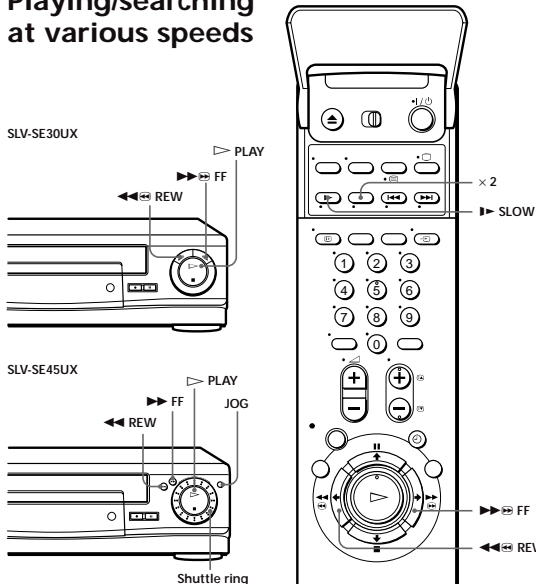

Playback options	Operation
View the picture during fast-forward or rewind	During fast-forward, hold down \gggg FF/ \gggg FF. During rewind, hold down \llll REW/ \llll REW.
Play at high speed	<ul style="list-style-type: none"> • During playback, press \gggg FF or \llll REW on the remote commander. • During playback, hold down \gggg FF/\gggg FF or \llll REW/\llll REW. When you release the button, normal playback resumes.
Play at twice the normal speed	During playback, press $\times 2$.
Play in slow motion	During playback, press \blacktriangleright SLOW.

Playback options	Operation
Play frame by frame	During pause, press $\blacktriangleright\blacktriangleright\blacktriangleright$ FF or $\blacktriangleleft\blacktriangleleft\blacktriangleleft$ REW on the remote commander. Hold down $\blacktriangleright\blacktriangleright\blacktriangleright$ FF or $\blacktriangleleft\blacktriangleleft\blacktriangleleft$ REW to play one frame each second.
Rewind and start play	During stop, press \blacktriangleright PLAY on the VCR while holding down $\blacktriangleleft\blacktriangleleft$ REW/ $\blacktriangleleft\blacktriangleleft$ REW on the VCR.

To resume normal playback
Press \blacktriangleright PLAY.

Using the shuttle ring (SLV-SE45UX only)

With the shuttle ring on the VCR, you can operate a variety of playback options. There are two ways for using the shuttle ring, normal mode and jog mode.

To use the shuttle ring in normal mode

During playback or pause, turn the shuttle ring clockwise or anticlockwise. Each change in the shuttle ring position changes the playback mode in the following way.

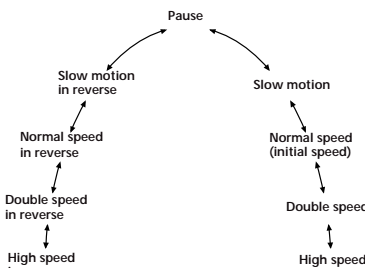

continued

To use the shuttle ring in jog mode

Use this mode for frame-by-frame playback.

Press JOG to enter the jog mode. The JOG button lights up. If you change to the jog mode during any playback mode, the playback pauses so you can see a still picture. Each change in the shuttle ring position shifts the picture one frame. To shift frames in reverse, turn the shuttle ring anticlockwise. The frame shift speed depends on the speed you turn the shuttle ring.

To resume normal mode, press JOG again. The JOG button goes off.

Tip

- Adjust the picture using the TRACKING +/- buttons if:
 - Streaks appear while playing in slow motion.
 - Bands appear at the top or bottom while pausing.
 - The picture shakes while pausing.
- To set tracking to the centre position, press both buttons (+/-) at the same time.

Notes

- The sound is muted during these operations.
- The picture may have snow when playing at high speed in reverse. (SLV-SE30UX only)
- In the LP mode, noise may appear or there may be no colour.

Setting the recording duration time

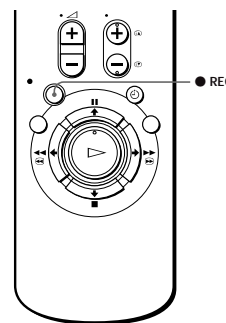

After starting recording in the normal way, you can have the VCR stop recording automatically after a specified duration.

- While recording, press ● REC. The ⌚ indicator appears in the display window.

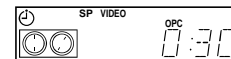

- Press ● REC repeatedly to set the duration. Each press advances the time in increments of 30 minutes.

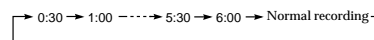

The tape counter decreases minute by minute to 0:00, then the VCR stops recording and turns off automatically.

To extend the duration

Press ● REC repeatedly to set a new duration.

To cancel the duration

Press ● REC repeatedly until the ⌚ indicator disappears and the VCR returns to normal recording mode.

To stop recording

To stop the VCR while recording, press ■ STOP.

Note

- You cannot display the current tape time in the display window when setting the recording duration.

Checking/ changing/ cancelling timer settings

Before you start...

- Turn on your TV and set it to the video channel.

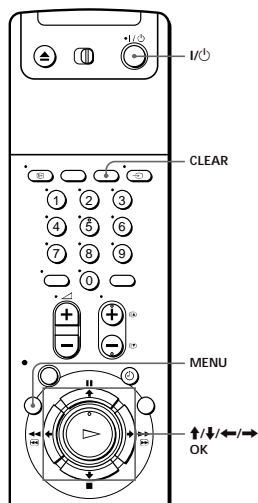

- Press I/O to turn on the VCR.
- Press MENU, then press ↑/↓ to highlight LISTS and press OK.
- Press ↑/↓ to highlight TIMER LIST, then press OK:

- If you want to change or cancel a setting, go on to the next step.
- If you do not need to change or cancel the settings, press MENU, then turn off the VCR to return to recording standby.

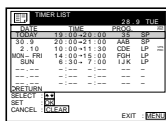

- Press ↑/↓ to select the setting you want to change or cancel, then press OK. The selected setting appears in the TIMER menu.

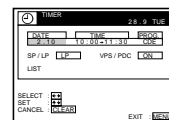

- To change the setting, press ←/→ to highlight the item you want to change, and press ↑/↓ to reset it.
 - To cancel the setting, press CLEAR.
 - Press MENU.
- If any settings remain, turn off the VCR to return to recording standby.

When the timer settings overlap

The programme that starts first has priority and the second programme starts recording only after the first programme has finished. If the programmes start at the same time, the programme listed first in the menu has priority.

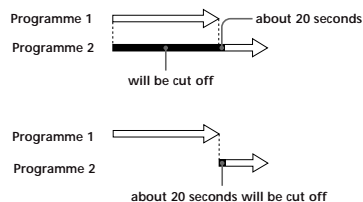

Searching using the Smart Search function

If you record multiple programmes on a tape, use the Smart Search function to see what has been recorded on your tape. You can see information such as date, time, and channel of programmes recorded on a tape. You can also start playback directly from the selected programme using the SMART SEARCH screen.

All programmes are listed on the screen, regardless of how the programme was recorded.

The data of the last tape inserted into the VCR is automatically stored in memory. If you want to recall the latest data screen, select LATEST DATA in the SMART SEARCH screen (see page 57).

Before you start...

- Turn on your TV and set it to the video channel.

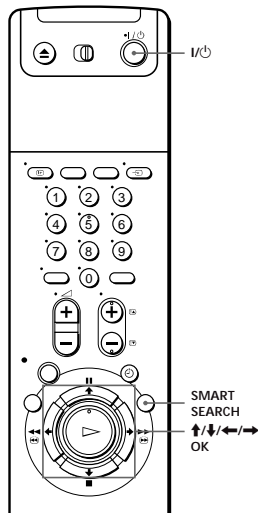

- 1 After recording, press I/O to turn on the VCR.
- 2 Press SMART SEARCH.
- 3 Press ↑/↓/←/→ to select the programme you want to start viewing.
- 4 Press OK.

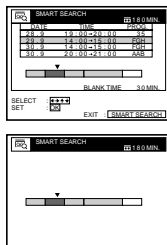

The VCR starts searching, and playback starts automatically from the beginning of the selected programme.

To stop searching
Press ■ STOP.

To exit the SMART SEARCH screen
Press SMART SEARCH.

To record in a blank space

Blank space on the tape will appear as a blank row in the SMART SEARCH screen. Select the blank row in step 3, then press OK. The VCR rewinds/fast-forwards the tape to the beginning of the blank space, then stops. Start recording.

To recall the latest data screen after you remove the tape

You can display the data of the last tape used to record a programme, even after you have removed the tape.

If you reinsert the tape and record additional programmes, be sure to select LATEST DATA. Otherwise, all of the data for the tape is deleted.

- 1 Reinsert the last tape that you used to record a programme.
- 2 Press SMART SEARCH.

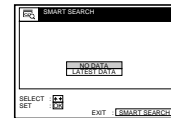

- 3 Press ↑/↓ to highlight LATEST DATA.

If you want to reset the latest data screen, highlight NO DATA and press OK, then record a programme.

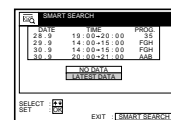

- 4 Press OK.

The latest data stored in the VCR's memory is displayed.

Tips

- You can store information for up to 24 programmes on a single list.
- While recording, you can display the SMART SEARCH screen using the SMART SEARCH button. If you decide to stop recording, press SMART SEARCH to make the SMART SEARCH screen disappear first. Then press ■ STOP.

continued

Searching using the Smart Search function (continued)

Notes

- If you begin recording a programme "D" from the middle of a previously recorded programme "A" and into another previously recorded programme "B," the Smart Search information for the second programme "B" which is recorded over is deleted.

Originally recorded programmes

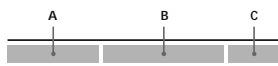

Recording the programme "D" over the programme "A" and "B"

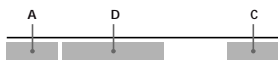

- You cannot use this function unless the clock is set.
- Depending on the tape, the total or remaining time may not appear correctly.
- When recording a short programme (less than 10 minutes in SP mode, or 20 minutes in LP mode), the Smart Search function may not be available or the programme information may not appear. Also, if you record a long programme directly after a short programme, the Smart Search information for the short programme may be deleted.
- Blank space is measured from the end of the last recorded programme to the end of the tape. However, if you eject the tape then make a new recording on the same tape, the original recorded programme(s) is displayed as a blank space.
- If no information is stored in the VCR's memory, LATEST DATA does not appear in the SMART SEARCH screen.

Searching using the index function

The VCR marks the tape with an index signal at the point where each recording begins. Use these signals as references to find a specific recording.

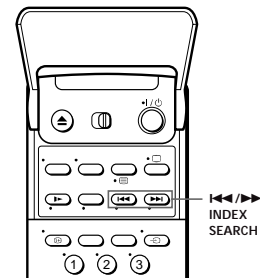

- 1 Insert an indexed tape into the VCR.
- 2 Press I◀◀/▶▶ INDEX SEARCH.

- To search ahead, press ▶▶ INDEX SEARCH.
- To search backwards, press I◀◀ INDEX SEARCH.

The VCR starts searching, and playback starts automatically from that point.

To stop searching

Press ■ STOP.

Note

- No index signal will be added when recording starts from recording pause. However, an index signal will be marked if you change the programme position during recording pause.

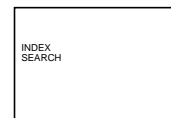

Adjusting the picture

Adjusting the tracking

Although the VCR automatically adjusts the tracking when playing a tape (the  indicator flashes in the display window, then goes off), distortion may occur if the tape was recorded in poor condition. In this case, manually adjust the tracking.

During playback, press TRACKING +/- to display the tracking meter. The distortion should disappear as you press one of the two buttons (the  indicator lights up). To resume automatic tracking adjustments, eject the tape and re-insert it.

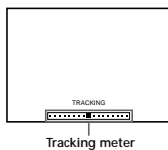

About the Optimum Picture Control (OPC) function

The Optimum Picture Control (OPC) function automatically improves recording and playback quality by adjusting the VCR to the condition of the video heads and tape. To maintain better picture quality, we recommend that you set OPC to ON in the OPTIONS-1 menu (with the OPC indicator in the display window lit). For details, see page 63.

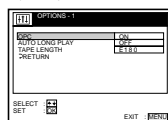

OPC playback

The OPC function automatically works on all types of tapes, including rental tapes and tapes that were not recorded with OPC.

OPC recording

Whenever you insert a tape and start recording for the first time, the VCR adjusts to the tape using the OPC function (the OPC indicator flashes rapidly). This adjustment is retained until the tape is ejected.

To deactivate the OPC function

Set OPC to OFF in the OPTIONS-1 menu. The OPC indicator in the display window goes off.

Tip

- To set tracking to the centre position, press the TRACKING + and - buttons at the same time.

Notes

- You can adjust the tracking for the NTSC-recorded tape but the tracking meter won't be displayed.
- With the Auto Long Play function on, the OPC function will work only in SP mode. If the tape speed automatically switches from SP to LP, the OPC function turns off. If, however, the entire programme is recorded in LP mode, the OPC function will work.
- There is a delay of about ten seconds before the VCR actually starts recording while the VCR analyses the tape. To avoid the delay, first set the VCR to recording pause (the OPC indicator flashes slowly) and press **REC** to have the VCR analyse the tape (the OPC indicator flashes rapidly). After the OPC indicator stops flashing, press **PAUSE** to start recording immediately. If you want to start recording quickly without using the OPC function, first set the VCR to recording pause (the OPC indicator flashes slowly) and press **PAUSE** to start recording.

Changing menu options

- Press MENU, then select OPTIONS and press OK.

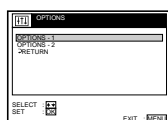

- Press **↑/↓** to highlight OPTIONS-1 or OPTIONS-2, then press OK.

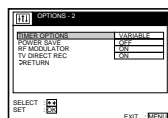
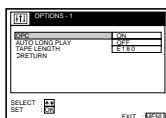

- Press **↑/↓** to select the option, then press OK.
- Press **↑/↓** to change the setting, then press OK.
- Press MENU to return to the original screen.

Menu choices

Initial settings are indicated in bold print.

OPTIONS-1

Menu option	Set this option to
OPC	<ul style="list-style-type: none"> ON to switch on the OPC (Optimum Picture Control) function and improve picture quality. OFF to switch off OPC.
AUTO LONG PLAY	<ul style="list-style-type: none"> ON to change the timer recording tape speed automatically to the LP mode when the remaining tape becomes shorter than the recording time. OFF to keep the set tape speed.
TAPE LENGTH	<ul style="list-style-type: none"> E180 to use an E-180 or shorter type tape. E195 to use an E-195 type tape. E240 to use an E-240 type tape. E300 to use an E-300 type tape.

OPTIONS-2

Menu option	Set this option to
TIMER OPTIONS	<ul style="list-style-type: none"> VARIABLE to display the TIMER METHOD menu for selecting STANDARD or VIDEO PLUS+ when pressing TIMER button. STANDARD to display the TIMER menu when pressing the TIMER button. VIDEO PLUS+ to display the VIDEO PLUS+ menu when pressing the TIMER button. <p>For details, see pages 42 and 47.</p>
POWER SAVE	<ul style="list-style-type: none"> ON to turn off the indicators in the display window to conserve the VCR power. OFF to turn on the indicators in the display window while the VCR is standing by.
RF MODULATOR	<ul style="list-style-type: none"> ON if you connect the VCR to your TV using only the aerial cable. OFF if you connect the VCR to your TV using the EURO-AV cable.
TV DIRECT REC	<ul style="list-style-type: none"> ON to activate the TV Direct Rec function. OFF to deactivate it.

Note

- When you set a timer recording, the indicators in the display window remain on, even though POWER SAVE is set to ON.

Editing with another VCR

How to connect to record on this VCR

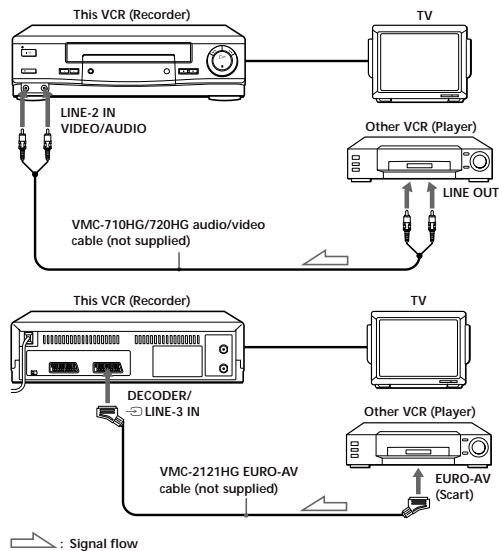

Tip
• You can also use the LINE-1 (TV) connector instead.

- Notes
- Make sure you connect the plugs to jacks of the same colour.
 - If you connect this VCR to both the LINE IN and LINE OUT jacks of the other VCR, select the input correctly to prevent a humming noise.
 - If the other VCR doesn't have a EURO-AV (Scart) connector, use the VMC-2106HG cable instead and connect the cable to the line out jacks of the other VCR.

Operation (when recording on this VCR)

- Before you start editing
- Turn on your TV and set it to the video channel.
 - Press INPUT SELECT to display "L2" ("L1" or "L3") in the display window.
 - Press SP/LP to select the tape speed, SP or LP.

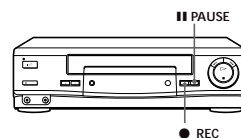

- 1 Insert a source tape with its safety tab removed into the other (playback) VCR. Search for the point to start playback and set it to playback pause.
- 2 Insert a tape with its safety tab in place into this (recording) VCR. Search for the point to start recording and press PAUSE.
- 3 Press REC on this VCR to set it to recording pause.
- 4 To start editing, press the PAUSE buttons on both VCRs at the same time.

To stop editing
Press the STOP buttons on both VCRs.

- Tip
- To cut out unwanted scenes while editing, press PAUSE on this VCR when an unwanted scene begins. When it ends, press PAUSE again to resume recording.
- Note
- If you start editing following the procedure above, the VCR won't start recording with the OPC function. To record a tape with the OPC function, press REC again during recording pause in step 3 so the VCR analyses the tape. Then, when you start editing in step 4, press PAUSE after the OPC indicator stops flashing. If you press PAUSE before the OPC indicator stops flashing, the OPC function is cancelled.

Index to parts and controls

Refer to the pages indicated in parentheses () for details.

Front panel (SLV-SE30UX)

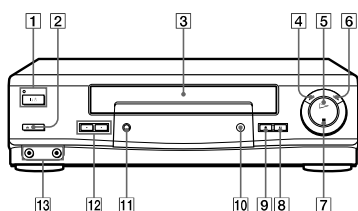

- | | |
|---|---|
| 1 I/ON/STANDBY switch/indicator (32) | 9 ● REC (recor d) button (38, 53, 65) |
| 2 EJECT button (35, 55) | 10 Remote sensor (5) |
| 3 Tape compar tment | 11 AUTO SET UP/RF (Radio Frequency) CHANNEL button (13, 14) |
| 4 ◀◀ REW (rewind) button (35, 50) | 12 PROGRAM/TRACKING +/- buttons (52, 60) |
| 5 ▷ PLAY button (35, 51) | 13 LINE-2 IN VIDEO/AUDIO jacks (64) |
| 6 ▶▶ FF (fast-for ward) button (35, 50) | |
| 7 ■ STOP button (35, 65) | |
| 8 ■ PAUSE button (32, 35, 65) | |

Front panel (SLV-SE45UX)

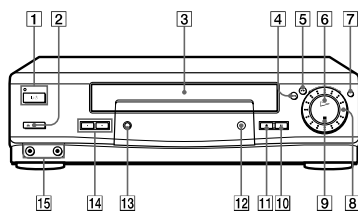

- | | |
|---|---|
| 1 I/ON/STANDBY switch/indicator (32) | 9 ■ STOP button (35, 65) |
| 2 EJECT button (35, 55) | 10 ■ PAUSE button (32, 35, 65) |
| 3 Tape compar tment | 11 ● REC (recor d) button (38, 53, 65) |
| 4 ◀◀ REW (rewind) button (35, 50) | 12 Remote sensor (5) |
| 5 ▶▶ FF (fast-for ward) button (35, 50) | 13 AUTO SET UP/RF (Radio Frequency) CHANNEL button (13, 14) |
| 6 ▷ PLAY button (35, 51) | 14 PROGRAM/TRACKING +/- buttons (52, 60) |
| 7 JOG button (52) | 15 LINE-2 IN VIDEO/AUDIO jacks (64) |
| 8 Shuttlering (51) | |

continued

Index to parts and controls (continued)

Display window

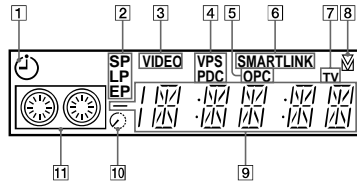

- 1 Timer indicator (44, 48)
- 2 Tape speed indicators (38)
- 3 VIDEO indicator (11, 39)
- 4 VPS (Video Programme System)/PDC (Programme Delivery Control) indicator (45)
- 5 OPC (Optimum Picture Control) indicator (60)
- 6 SMARTLINK indicator (11)
- 7 TV indicator (41)
- 8 Tracking indicator (60)
- 9 Time counter/clock/line/programme position indicator (35, 38, 65)
- 10 Remaining time indicator (39)
- 11 Tape/recording indicator (38)

Rear panel

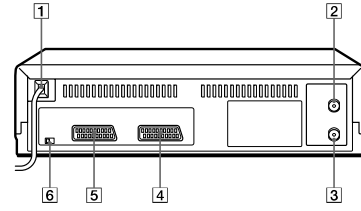

- 1 Mains lead (9, 10)
- 2 AERIAL IN ANTENNE ENTREE connector (9, 10)
- 3 AERIAL OUT ANTENNE SORTIE connector (9, 10)
- 4 LINE-3 IN ENTREE LIGNE-3 connector (64)
- 5 LINE-1 (TV) LIGNE-1 (TV) connector (10)
- 6 NTSC PB (Play Back) switch (35)

continued

Index to parts and controls (continued)

Remote commander

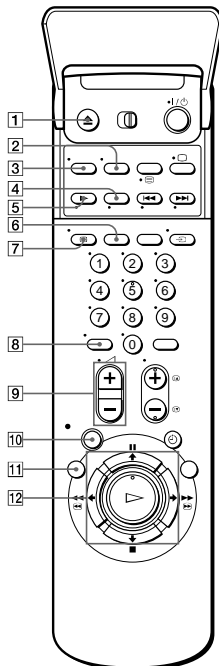

- 1 EJECT button (35)
- 2 WIDE button (for TV) (7)
- 3 AUDIO MONITOR button (for TV) (7)
- 4 x2 button* (50)
- 5 SLOW button* (50)
- 6 SP (Standard Play)/LP (Long Play) button (38)
- 7 DISPLAY button (39)
- 8 -- (ten's digit) button (6, 40)
- 9 (volume) +/- buttons (for TV) (6)
- 10 REC (record) button (38, 53)
- 11 MENU button (16, 54, 62)
- 12 PAUSE button (16, 35)
- STOP button (16, 35)
- REW (rewind) button (35, 50)
- FF (fast forward) button (35, 50)
- PLAY/OK button (16, 35)

* FASTTEXT buttons (for TV)

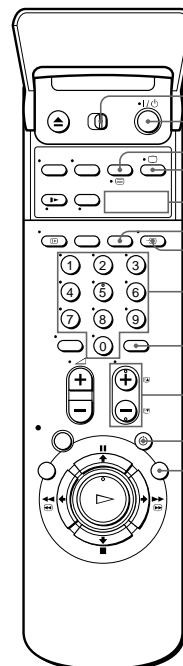

- 13 TV/VIDEO remote control switch (5)
- 14 I/O (on/standby) switch (6, 44)
- 15 COUNTER/REMAIN button (39)
- 16 Teletext button (for TV) (7)
- 17 TV power on/TV mode select button (for TV) (7)
- 18 INDEX SEARCH buttons* (59)
- 19 CLEAR button (35, 43, 55)
- 20 TV/VIDEO button (6, 11, 39)
- 21 Programme number buttons (6, 40)
- 22 INPUT SELECT button (38, 48, 65)
- 23 PROG (programme) +/- buttons (6, 18, 38)
- 24 Teletext page access buttons (for TV) (7)
- TIMER button (42, 47)
- SMART SEARCH button (56)

* FASTTEXT buttons (for TV)

SECTION 2 DISASSEMBLY

NOTE: Follow the disassembly procedure in the numerical order given.

2-1. CASE, FRONT PANEL BLOCK ASSEMBLY

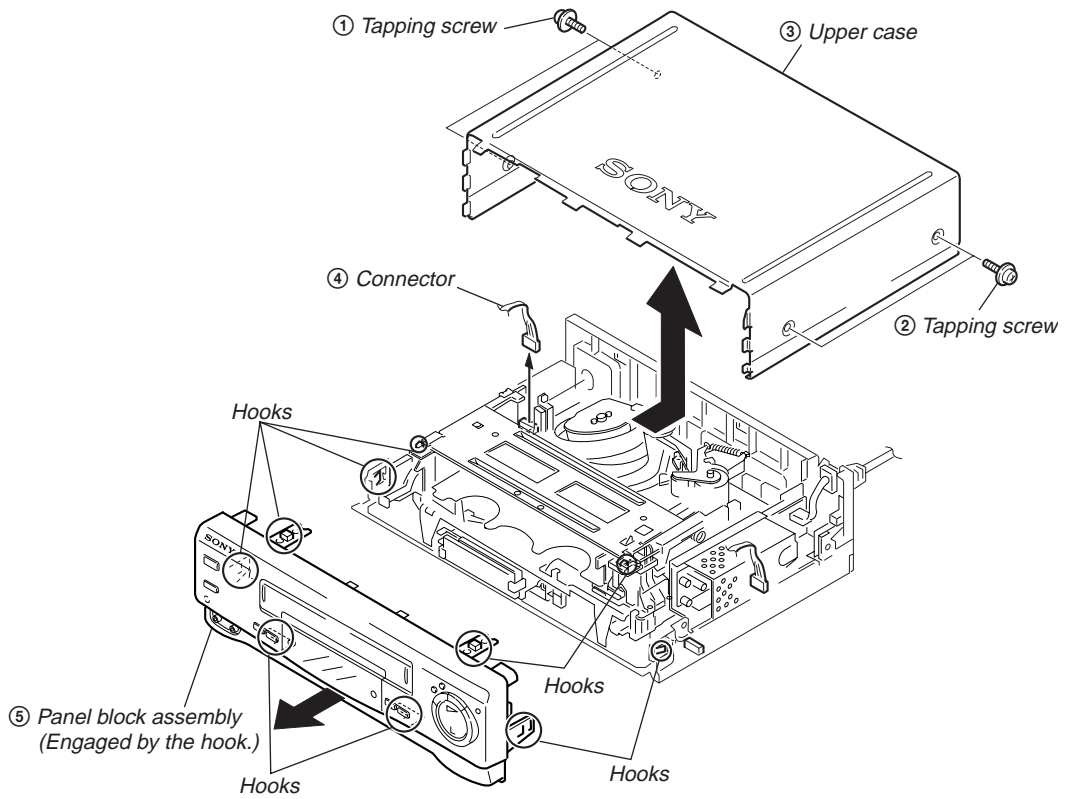

2-2. FI-15 BOARD, DS-83 BOARD

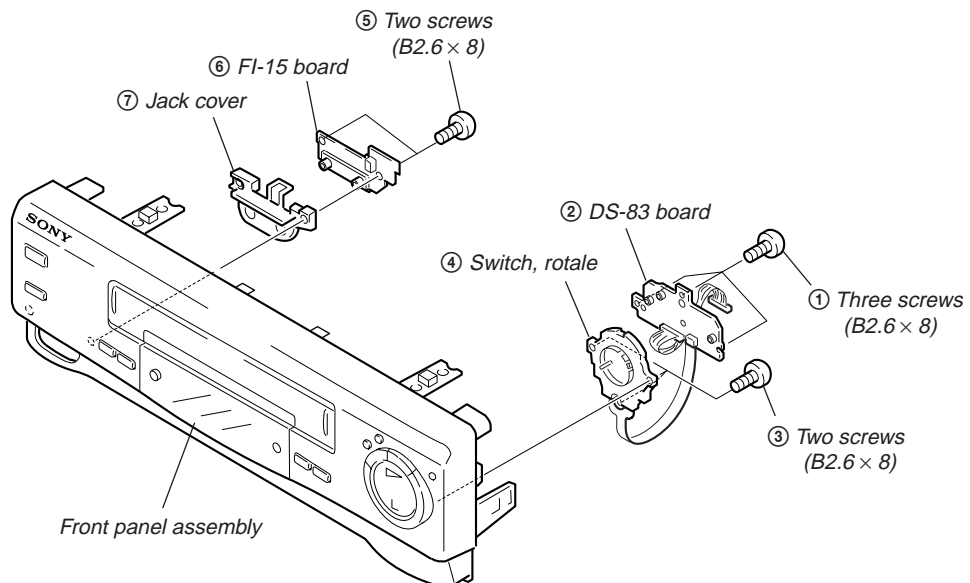

2-3. REAR PANEL

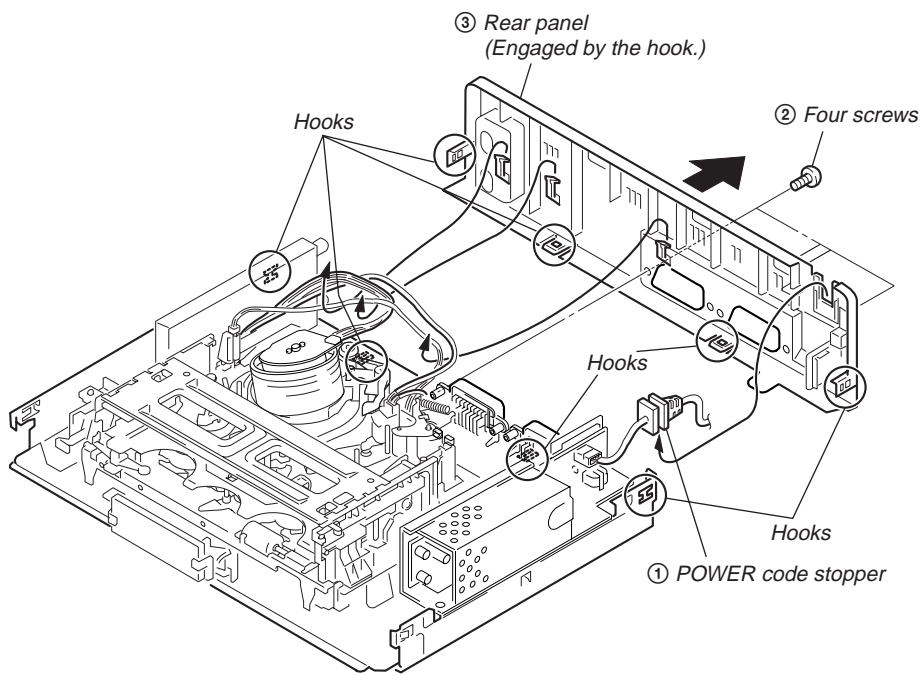

2-4. POWER BLOCK, MA-338 BOARD (WITH S MECHANISM DECK)

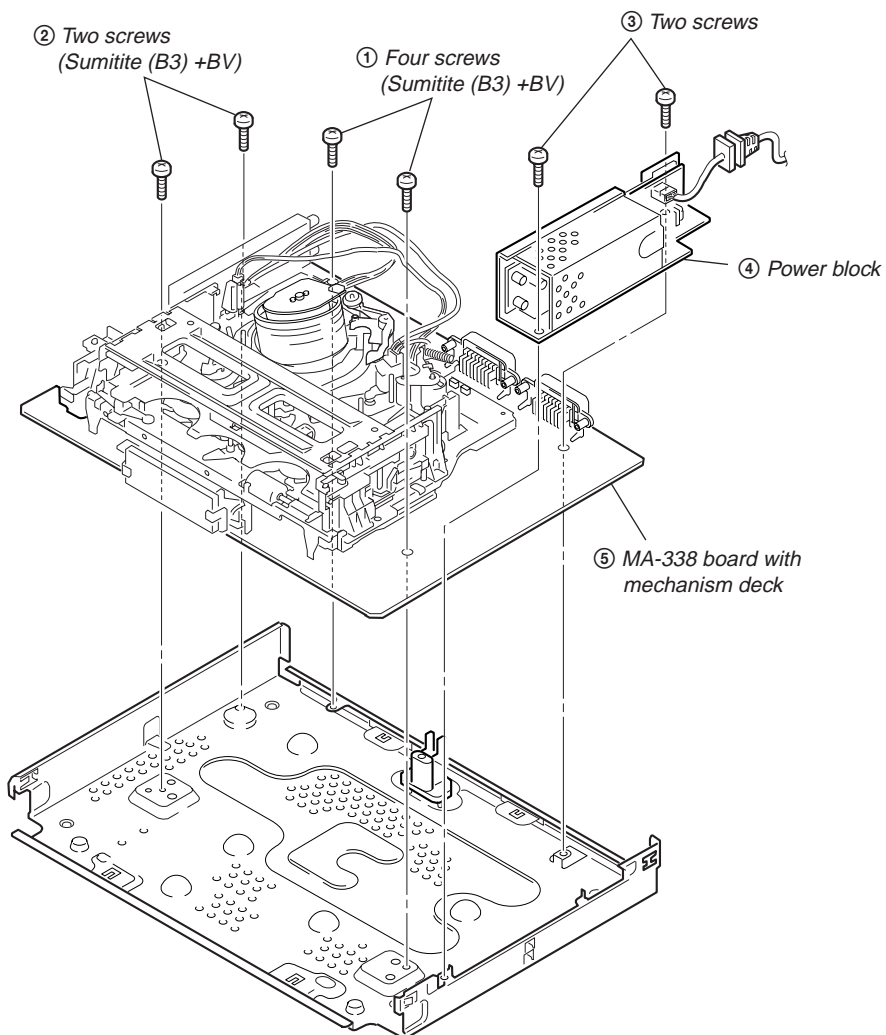

2-5. S MECHANISM DECK

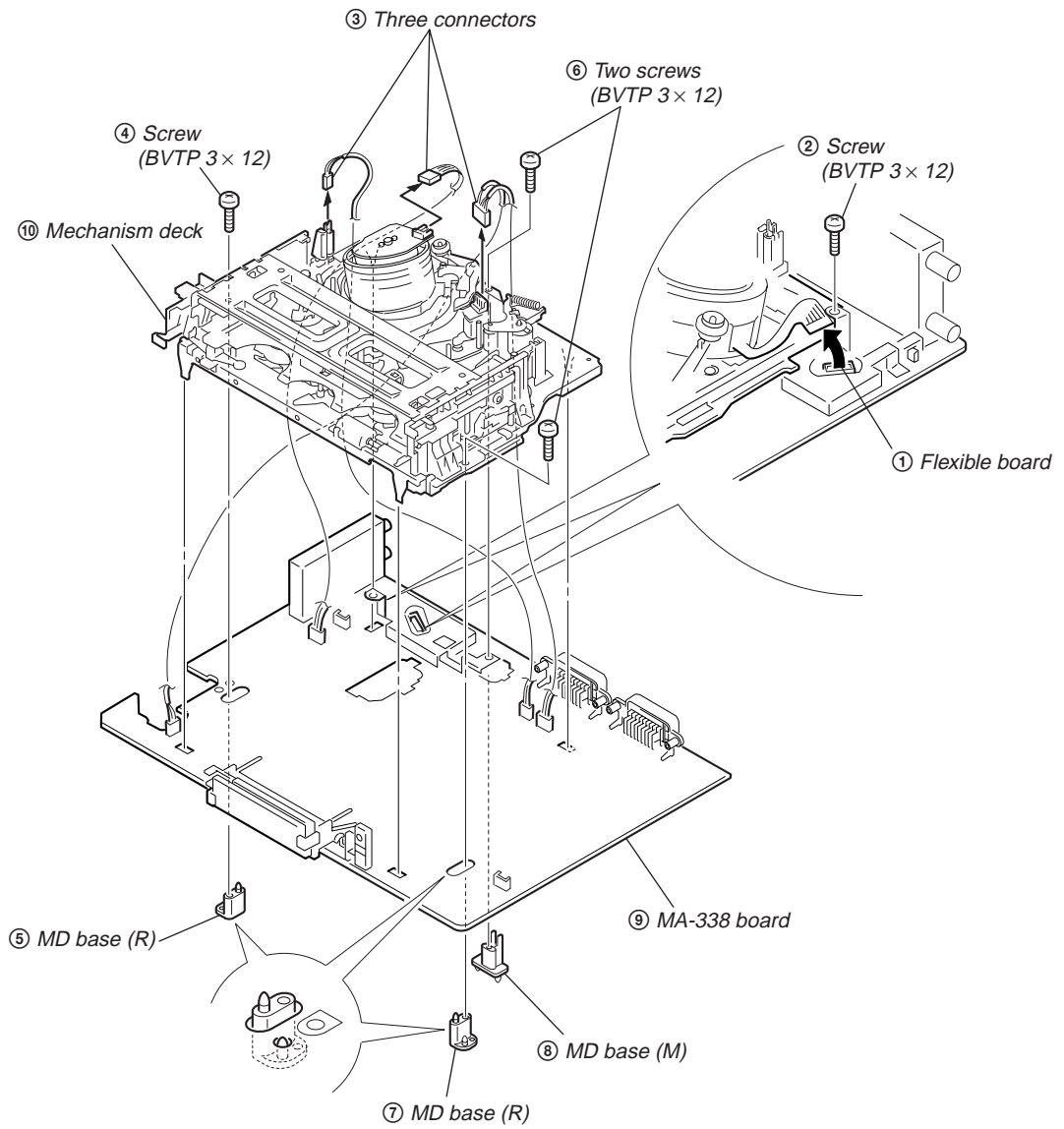

2-6. INTERNAL VIEWS

— Top View —

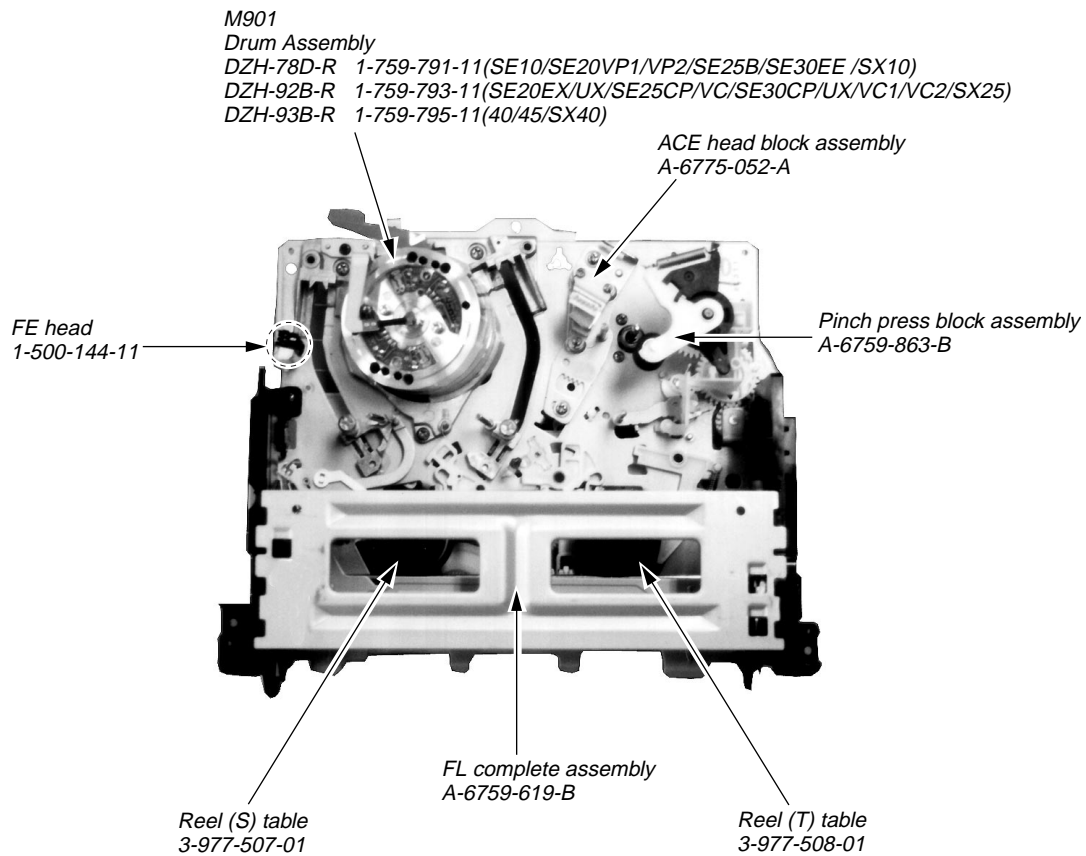

— Bottom View —

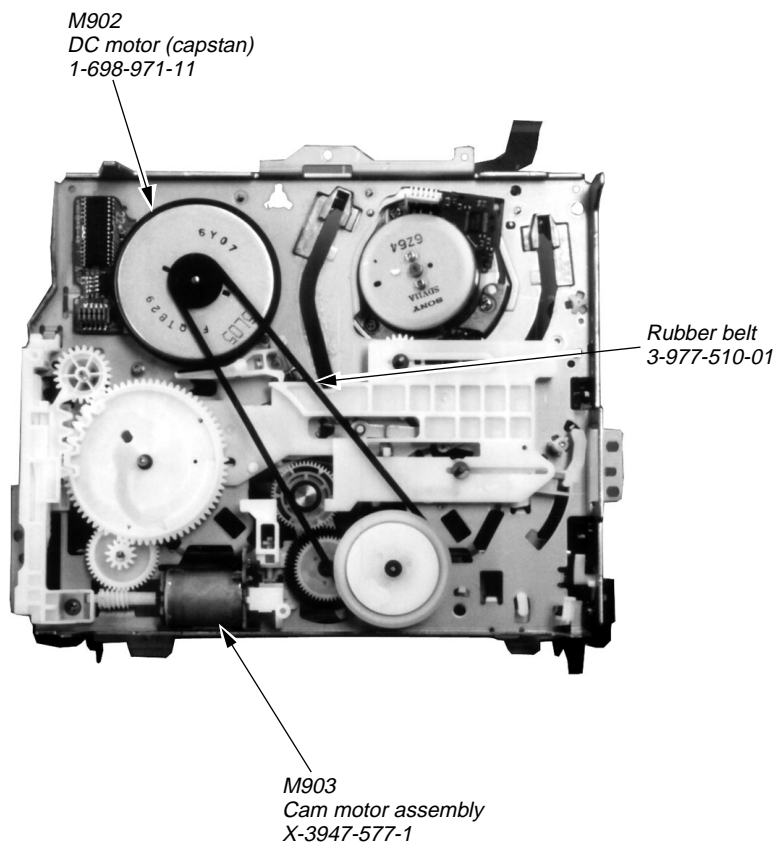

2-7. CIRCUIT BOARDS LOCATION

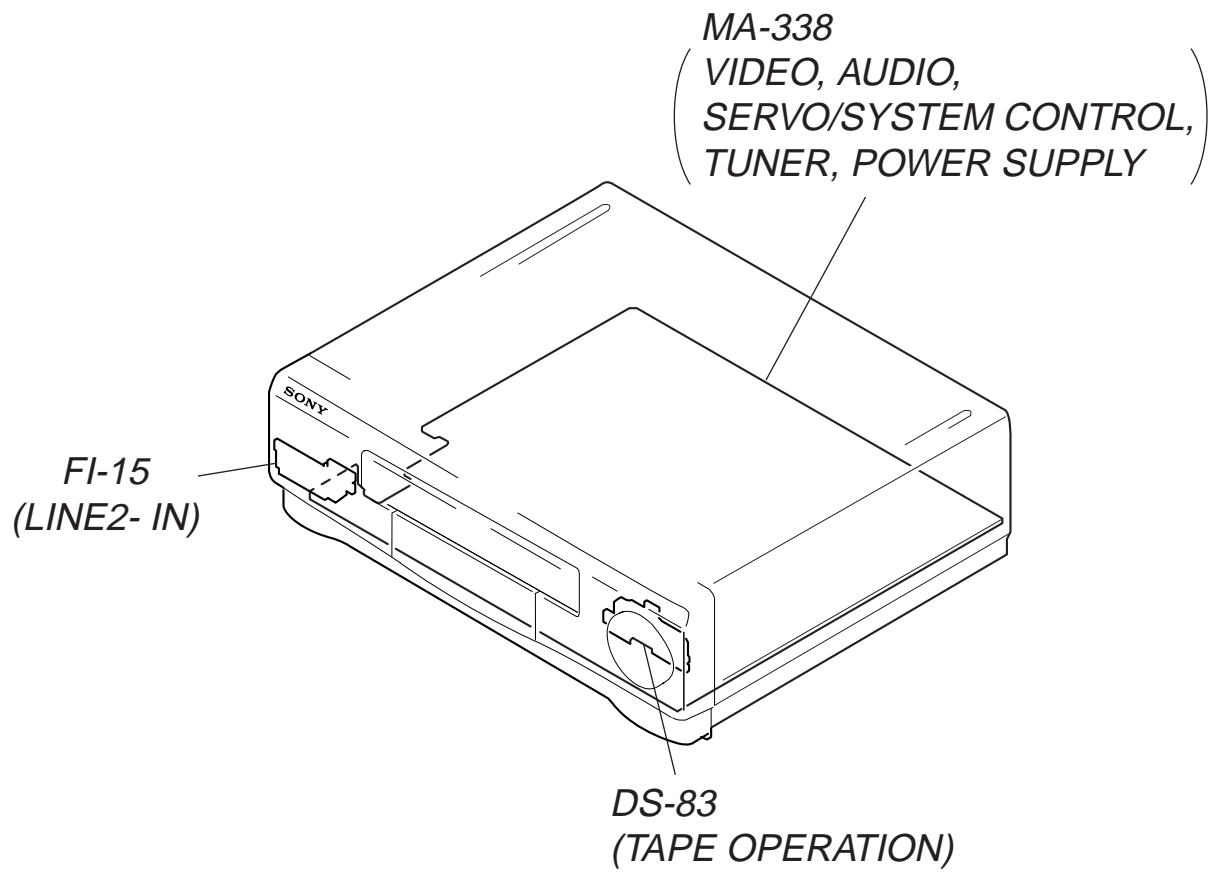

SECTION 3
BLOCK DIAGRAMS

3-1. OVERALL BLOCK DIAGRAMS

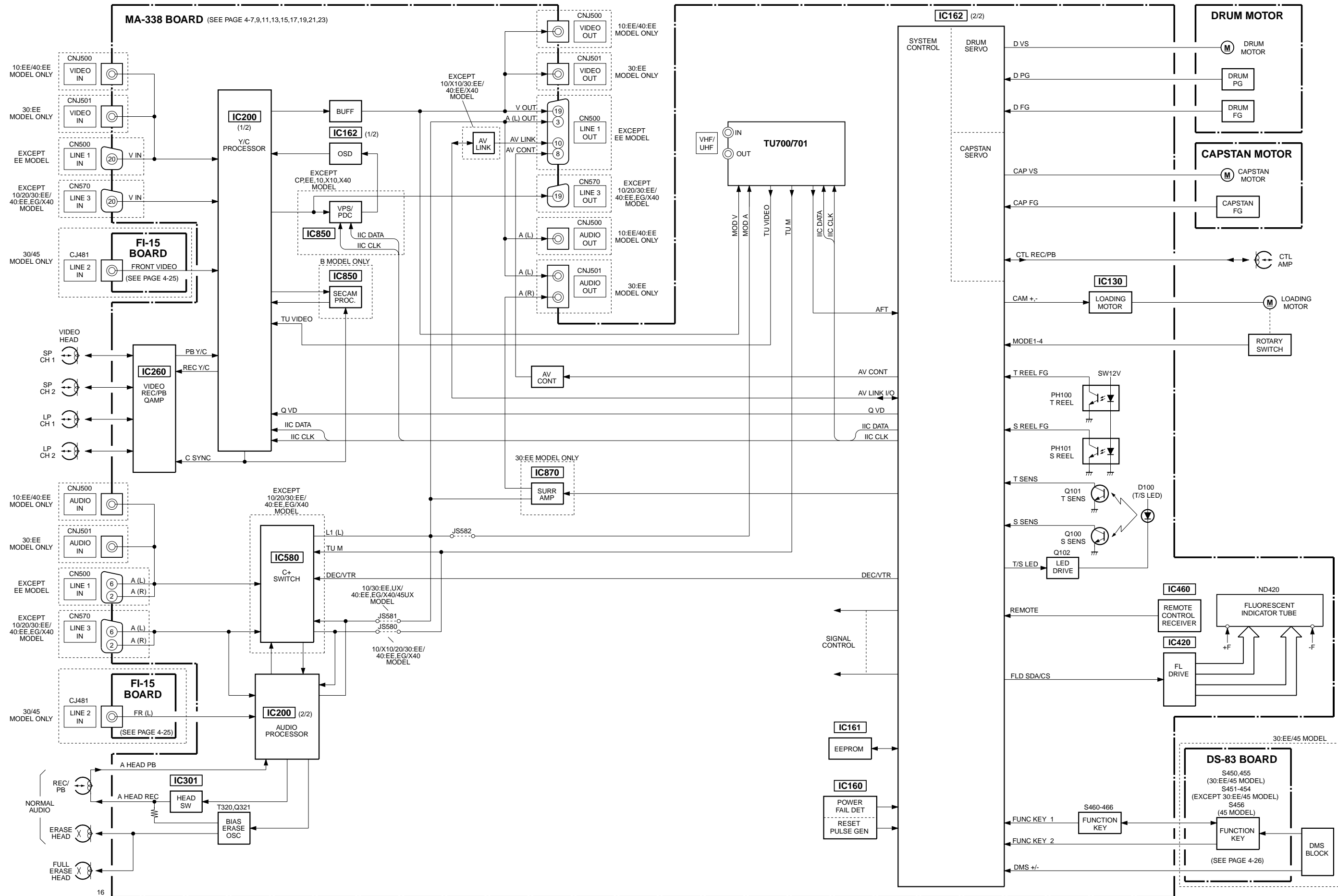

3-2. VIDEO BLOCK DIAGRAM

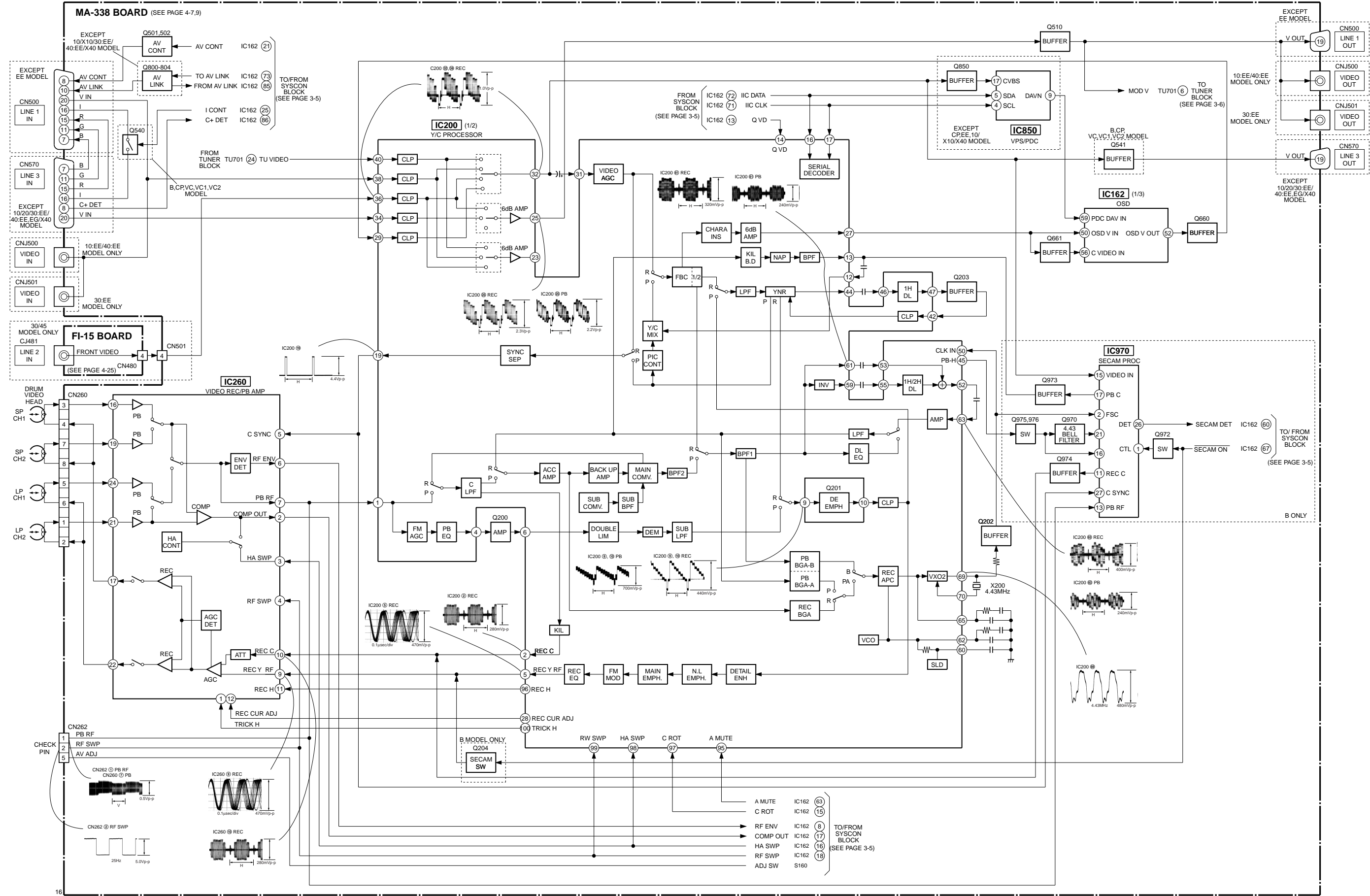

16

3-3. SERVO/SYSTEM CONTROL/TUNER BLOCK DIAGRAM

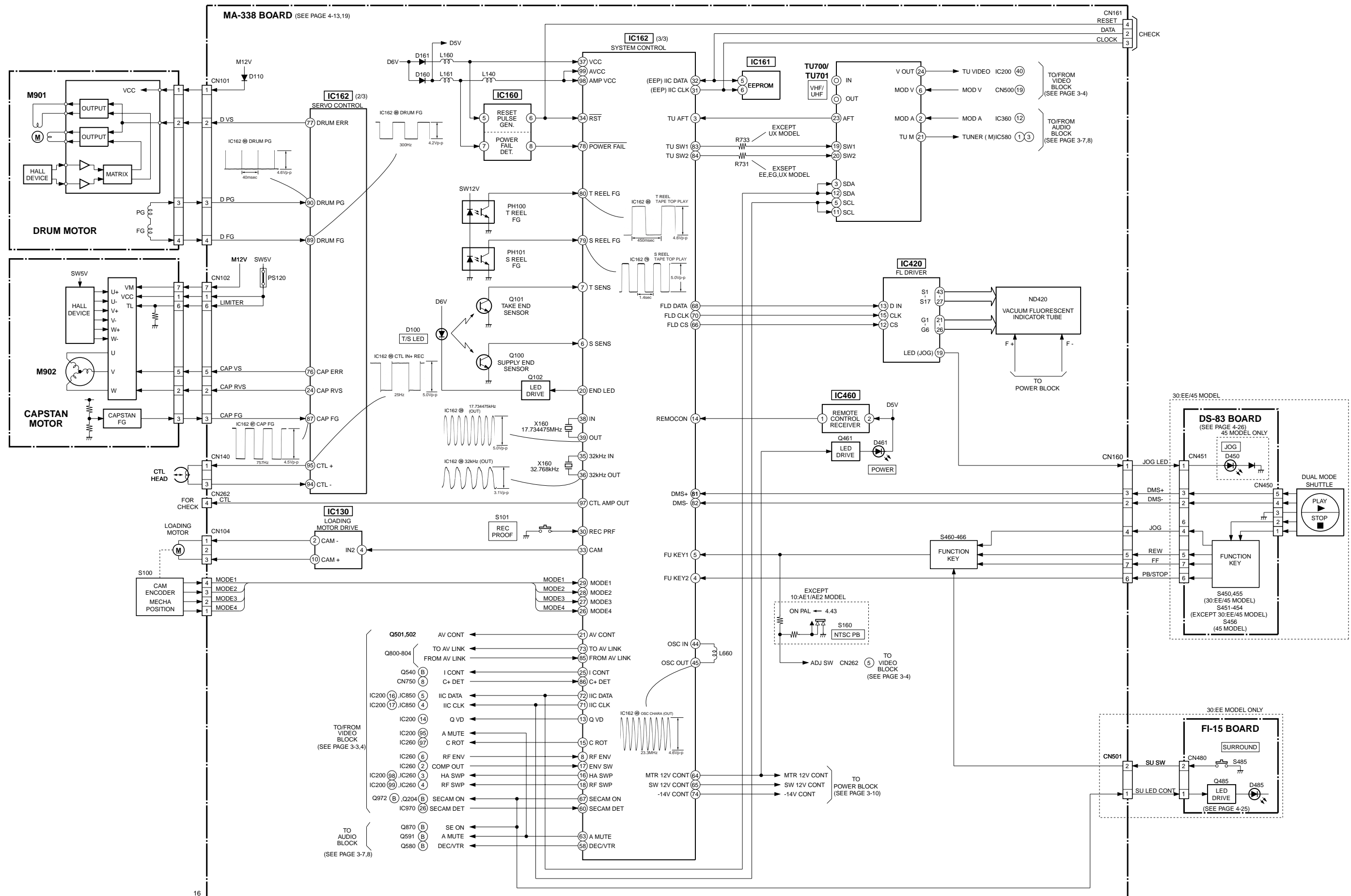

16

3-4. AUDIO BLOCK DIAGRAM

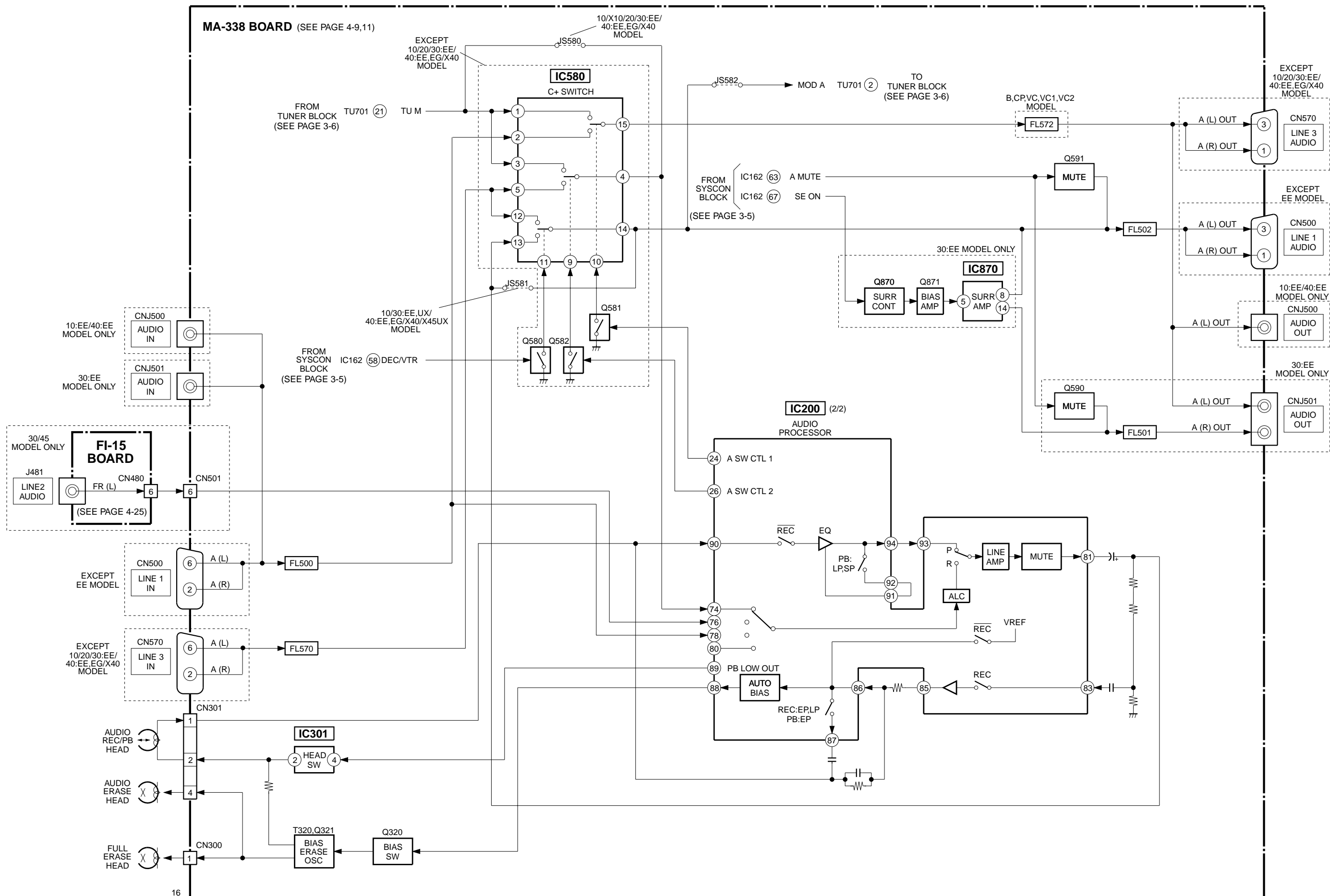

3-5. POWER BLOCK DIAGRAM

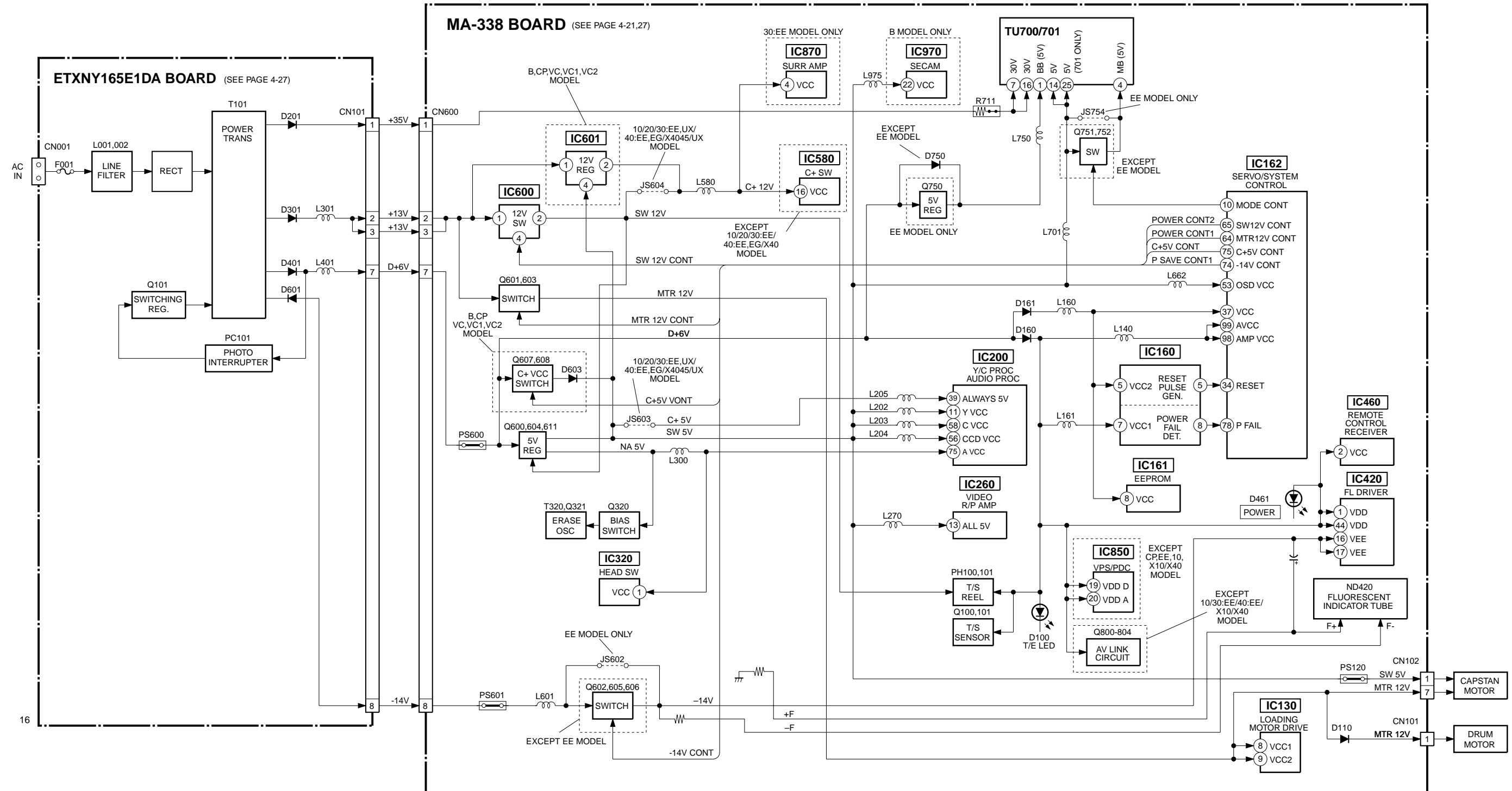

SECTION 4 PRINTED WIRING BOARDS AND SCHEMATIC DIAGRAMS

**THIS NOTE IS COMMON FOR PRINTED WIRING BOARDS AND SCHEMATIC DIAGRAMS.
(In addition to this, the necessary note is printed in each block.)**

(For printed wiring boards)

- : Pattern from the side which enables seeing.
(The other layers' patterns are not indicated.)
- Through hole is omitted.
- Circled numbers refer to waveforms.
- There are few cases that the part printed on diagram isn't mounted in this model.
- Chip parts.

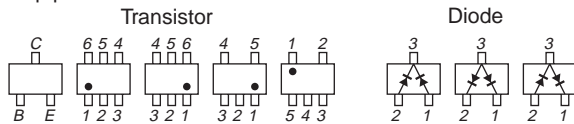

(For schematic diagrams)

- All capacitors are in μF unless otherwise noted. $\text{pF} : \mu\mu\text{F}$.
50V or less are not indicated except for electrolytics and tantalums.
- Chip resistors are 1/10W unless otherwise noted.
 $\text{k}\Omega=1000\Omega$, $\text{M}\Omega=1000\text{k}\Omega$.
- Caution when replacing chip parts.
New parts must be attached after removal of chip.
Be careful not to heat the minus side of tantalum capacitor, Because it is damaged by the heat.
- Some chip part will be indicated as follows.

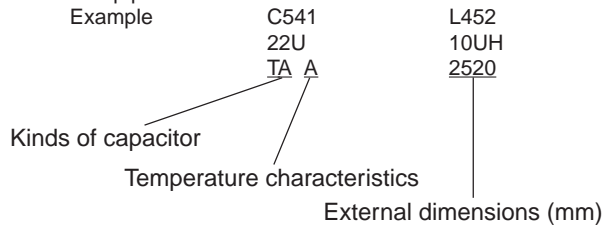

- Constants of resistors, capacitors, ICs and etc with XX indicate that they are not used.
In such cases, the unused circuits may be indicated.
- Parts with ★ differ according to the model/destination.
Refer to the mount table for each function.
- All variable and adjustable resistors have characteristic curve B, unless otherwise noted.
- Signal name
 $\text{XEDIT} \rightarrow \text{EDIT}$ $\text{PB/XREC} \rightarrow \text{PB/REC}$
- : non flammable resistor
- : fusible resistor
- : panel designation
- \triangle : internal component.
- $\text{B}+$: B+ Line.
- $\text{B}-$: B- Line.
- Circled numbers refer to waveforms.
- Readings are taken with a color-bar signal input.
- Voltage are dc between ground and measurement points.
- Readings are taken with a digital multimeter ($\text{DC}10\text{M}\Omega$).
- Voltage variations may be noted due to normal production tolerances.
- : adjustment for repair.
- Circled numbers refer to waveforms.

When indicating parts by reference number, please include the board name.

Note :
The components identified by mark \triangle or dotted line with mark \triangle are critical for safety.
Replace only with part number specified.

Note :
Les composants identifiés par une marque \triangle sont critiques pour la sécurité.
Ne les remplacer que par une pièce portant le numéro spécifié.

- Abbreviation
X10 : SX10
X25 : SX25
X40 : SX40

MA-338 BOARD
(SERVO/SYSTEM CONTROL BLOCK)

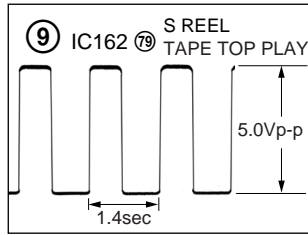
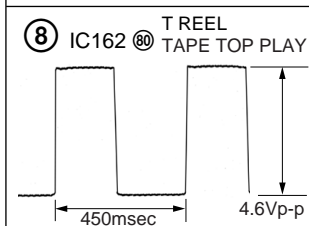
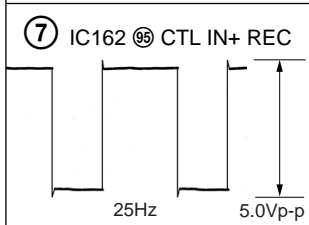
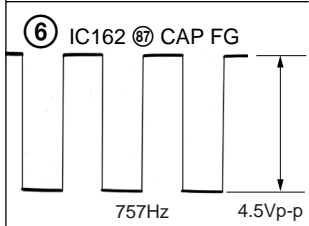
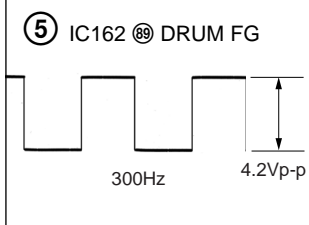
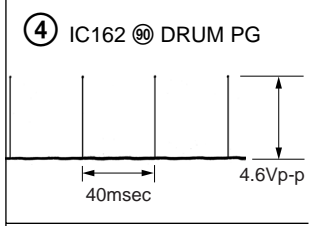
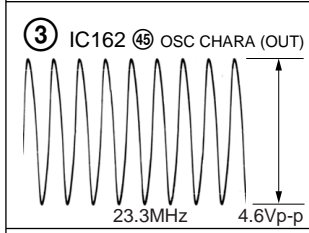
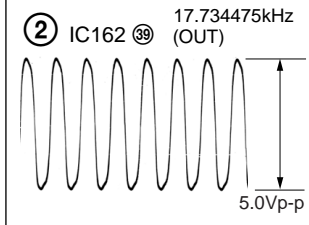
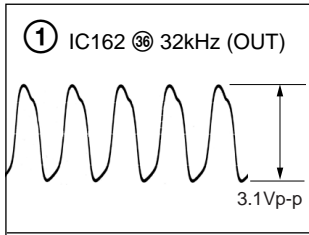

(REC/PB BLOCK)

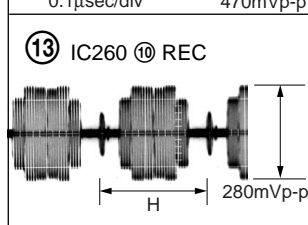
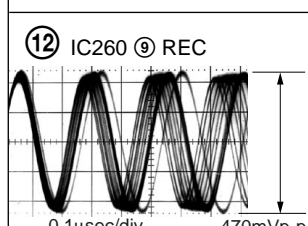
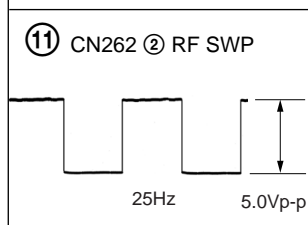
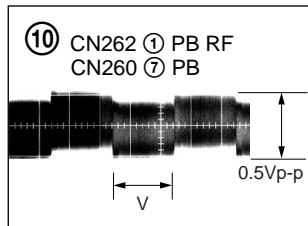

(VIDEO BLOCK)

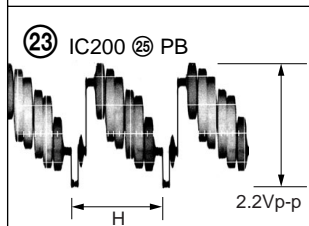
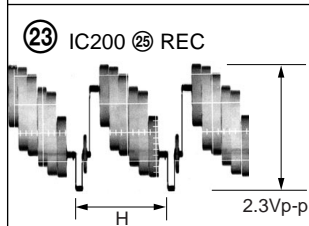
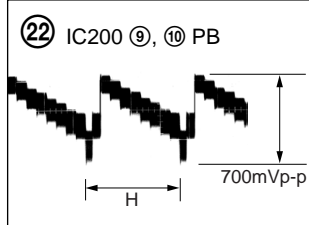
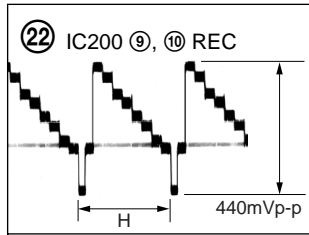
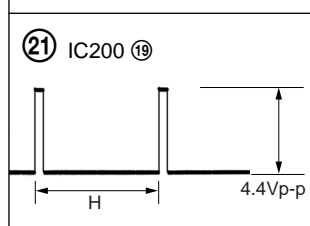
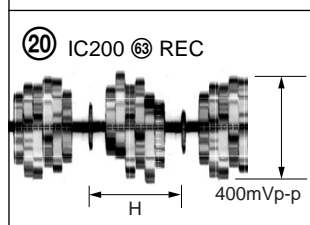
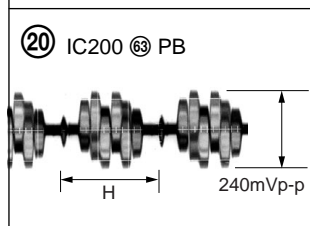
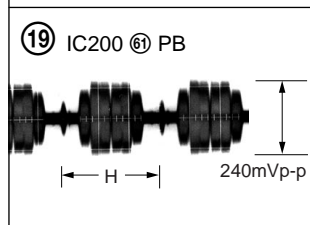
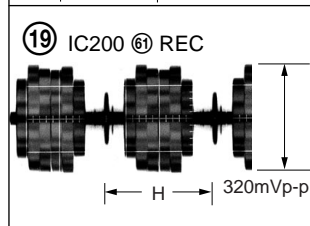
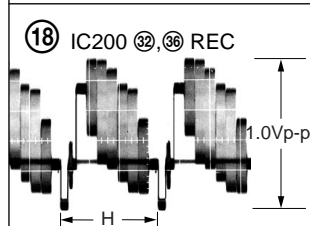
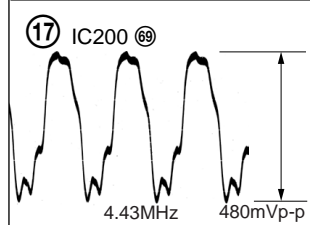
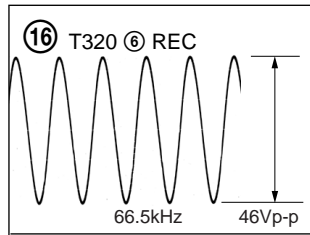
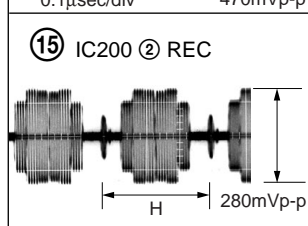
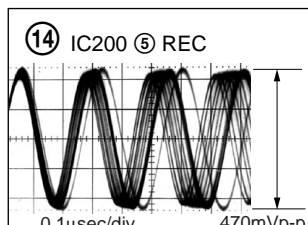

(DISPLAY BLOCK)

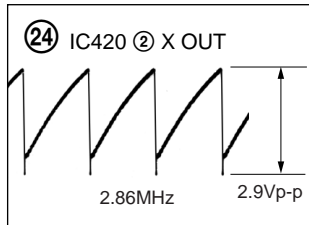

4-1. FRAME SCHEMATIC DIAGRAM

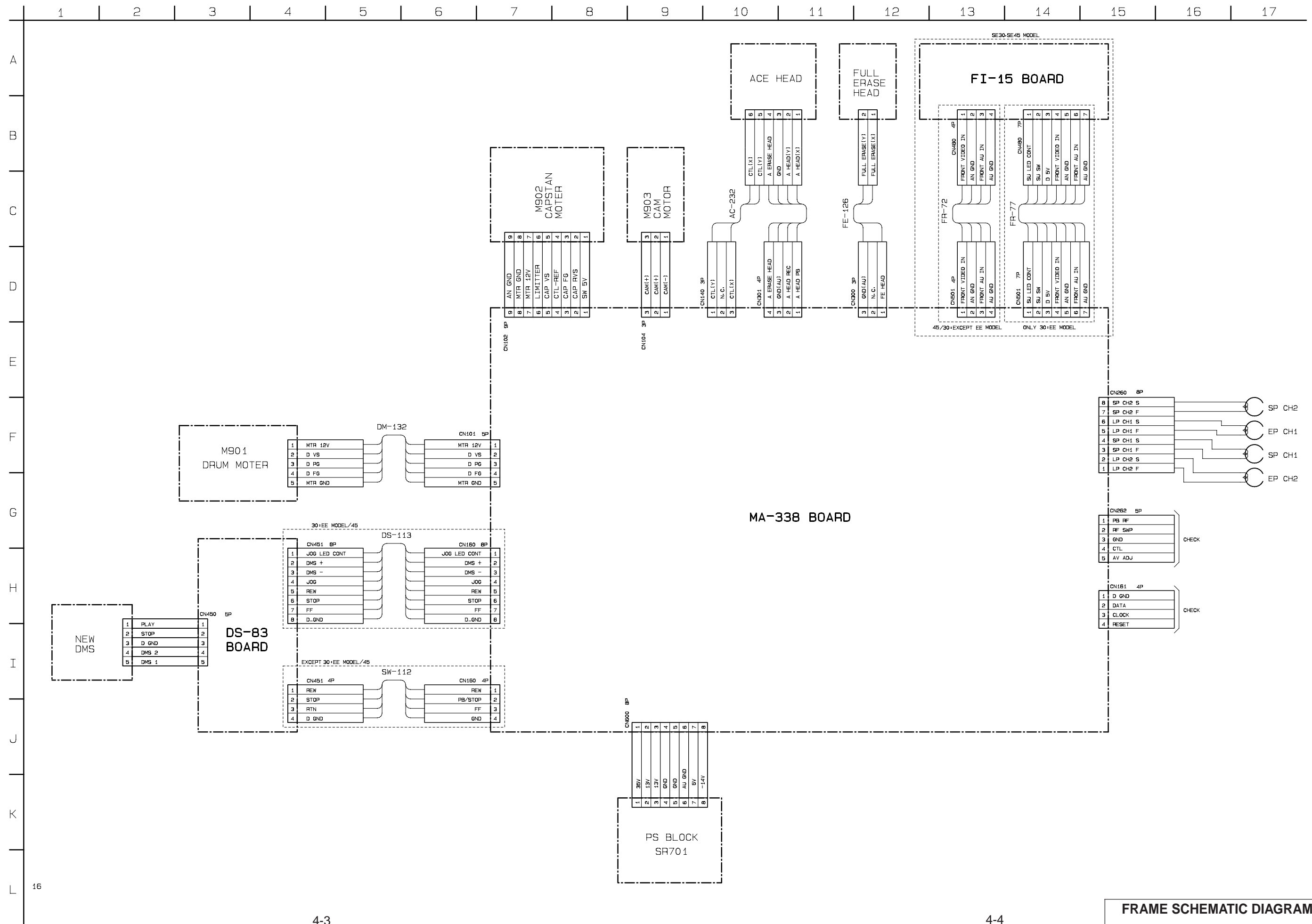

4-2. PRINTED WIRING BOARDS AND SCHEMATIC DIAGRAMS
MA-338 (VIDEO, AUDIO, SERVO/SYSTEM CONTROL, TUNER) PRINTED WIRING BOARD
 — Ref. No. MA-338 Board:1,000 Series —

There are few cases that the part printed on this diagram isn't mounted in this model.

MA-338 BOARD

CN101 F-12	IC162 B-10
CN102 F-3	IC200 G-5
CN104 B-6	IC260 I-9
CN140 A-12	IC320 G-7
CN160 B-1	IC420 A-7
CN161 C-12	IC460 A-5
CN260 I-10	
CN262 I-9	IC580 H-10
CN300 I-6	IC600 A-2
CN301 I-5	IC850 E-12
CN500 J-2	
CN501 F-12	Q101 E-3
CN570 J-6	Q102 C-7
CN600 D-1	Q200 H-6
	Q201 H-5
	Q202 E-5
D100 D-7	Q203 F-5
D110 F-11	Q203 F-5
D146 F-1	Q320 G-8
D160 E-2	Q321 G-7
D161 D-9	Q461 A-13
D162 A-13	Q501 I-1
D163 B-1	Q502 I-1
D461 A-13	Q510 I-3
D500 I-1	Q580 G-11
D504 I-1	Q581 G-11
D508 I-2	Q582 G-12
D510 I-3	Q583 H-10
D511 I-5	Q591 J-11
D512 I-3	Q600 E-2
D513 I-4	Q601 C-2
D515 I-4	Q602 B-2
D540 J-7	Q603 D-2
D544 I-3	Q604 E-1
D570 I-5	Q605 B-2
D571 J-5	Q606 A-2
D590 J-11	Q611 F-7
D591 I-11	Q660 B-9
D600 E-1	Q661 C-9
D601 E-1	Q751 H-12
D602 E-1	Q752 H-12
D702 G-12	Q800 B-3
D750 I-12	Q801 B-3
D800 B-3	Q802 B-3
	Q803 B-3
IC130 B-4	Q804 B-3
IC160 C-11	Q850 E-11
IC161 C-11	

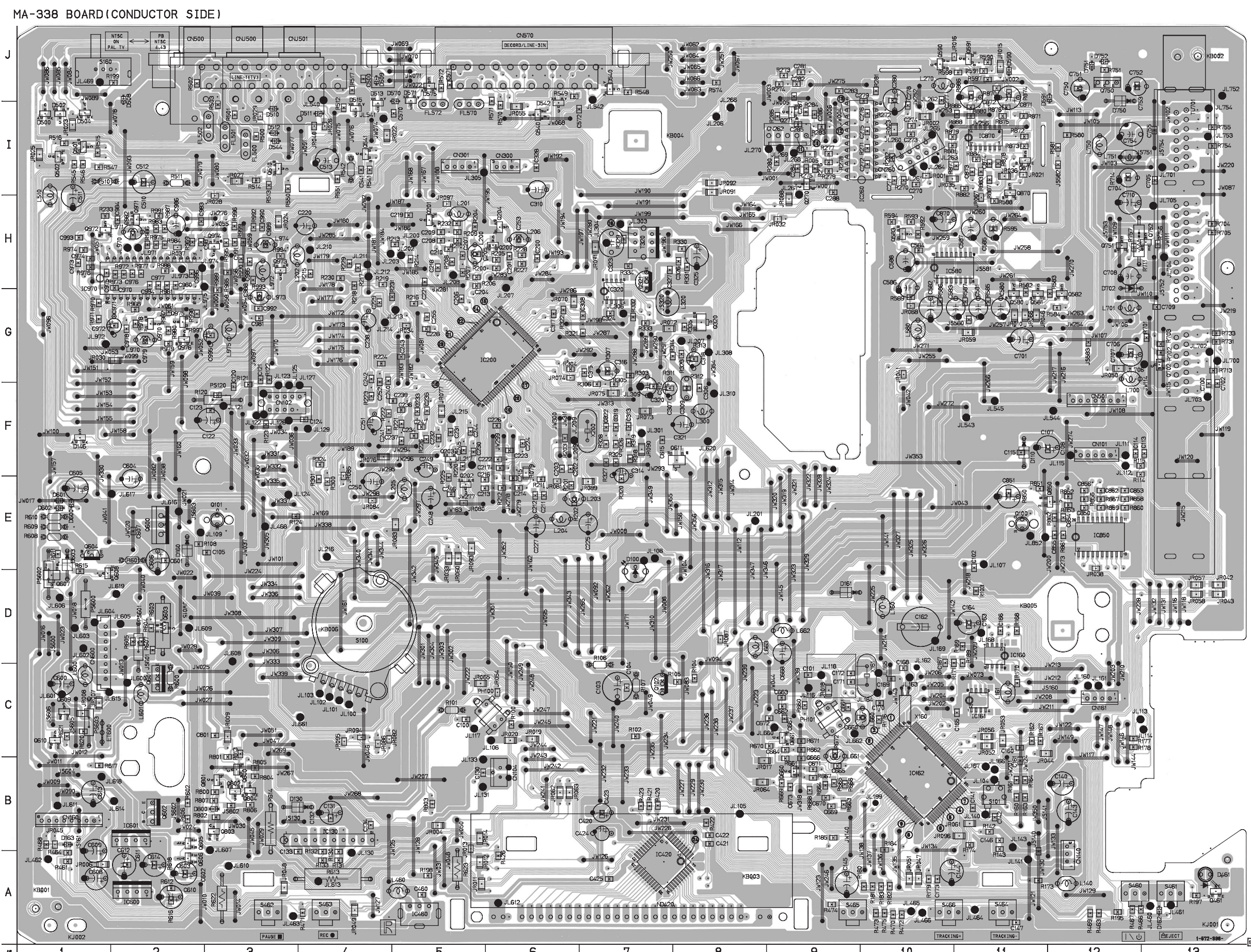

MA-338 (1/9) (REC/PB) SCHEMATIC DIAGRAM
 — Ref. No. MA-338 Board:1,000 Series —

For schematic diagram
 • Refer to page 4-5 for printed wiring board.
 • Refer to page 4-2 for waveforms.

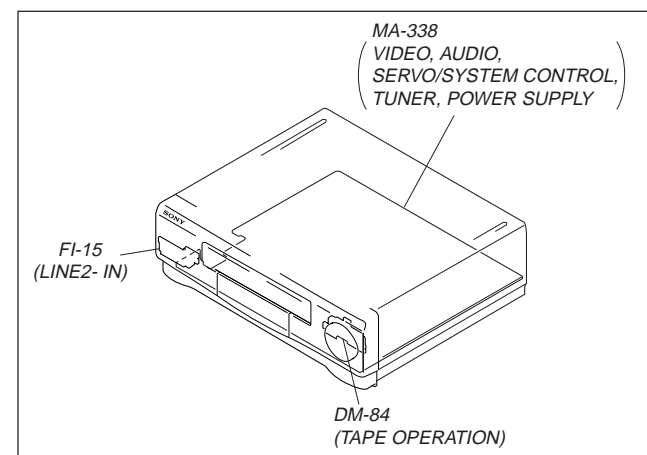
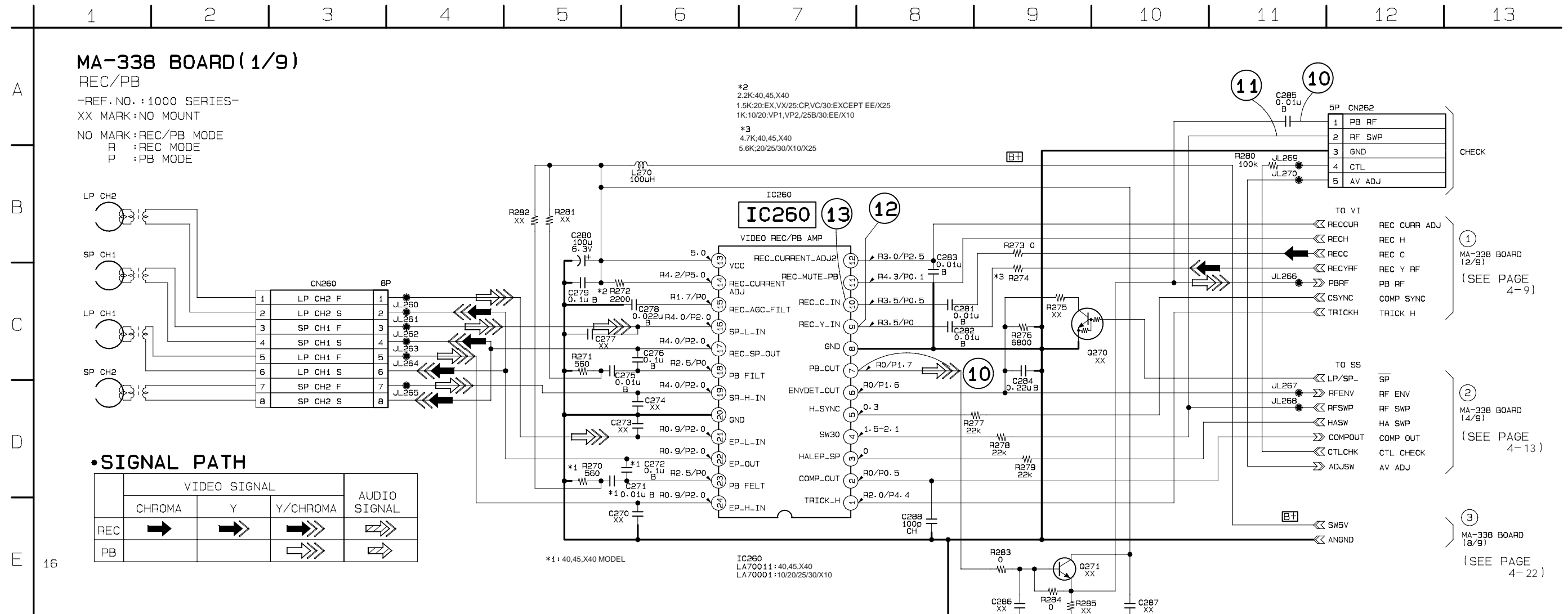

MA-338 (2/9) (VIDEO/AUDIO) SCHEMATIC DIAGRAM

— Ref. No. MA-338 Board:1,000 Series —

For schematic diagram

- Refer to page 4-5 for printed wiring board.
- Refer to page 4-2 for waveforms.

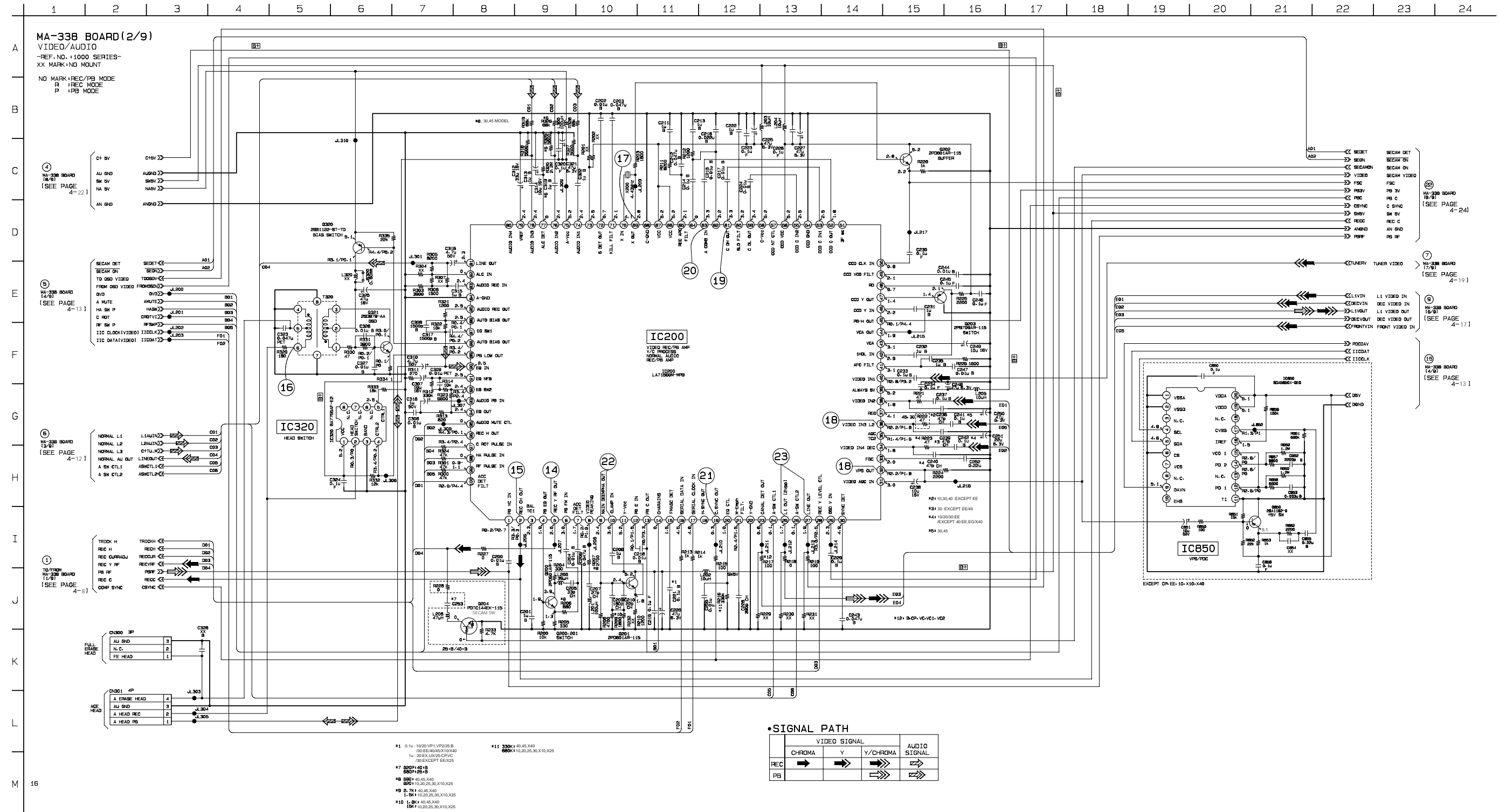

MA-338 (3/9) (AUDIO) SCHEMATIC DIAGRAM
 — Ref. No. MA-338 Board:1,000 Series —

For schematic diagram
 • Refer to page 4-5 for printed wiring board.

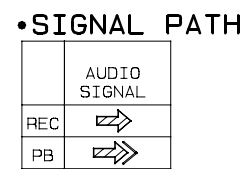
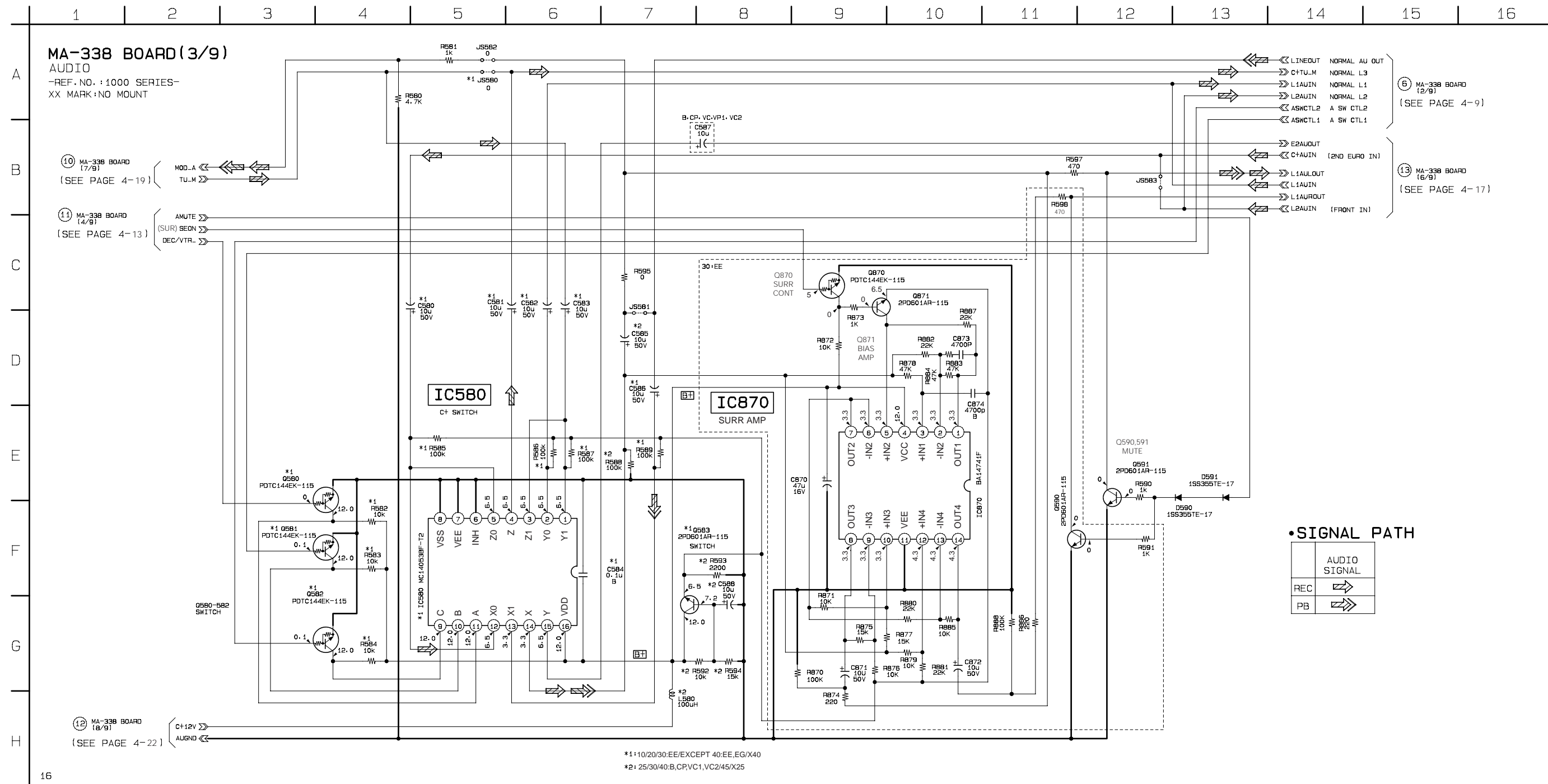

*1: 10/20/30/EE/EXCEPT 40:EE,EG/X40
 *2: 25/30/40:B,CP,VC1,VC2/45/X25

MA-338 (4/9) (SERVO/SYSTEM CONTROL) SCHEMATIC DIAGRAM

— Ref. No. MA-338 Board:1,000 Series —

For schematic diagram
 • Refer to page 4-5 for printed wiring board.
 • Refer to page 4-2 for waveforms.

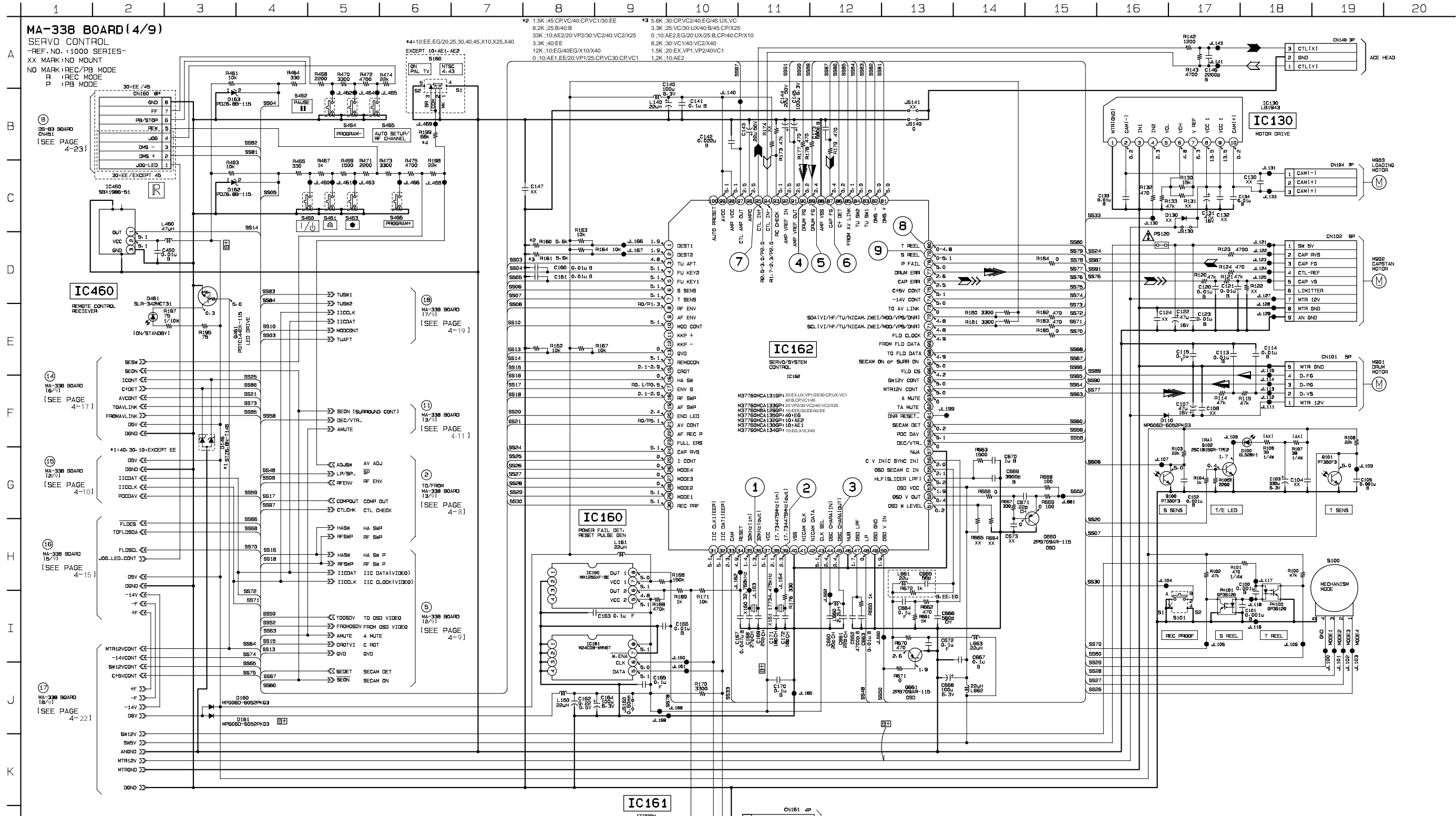

Note:
 The components identified by mark **▲** or dotted line with mark **▲** are critical for safety. Replace only with part number specified.

Note:
 Les composants identifiés par une marque **▲** sont critiques pour la sécurité. Ne les remplacer que par une pièce portant le numéro spécifié.

• SIGNAL PATH

	REC	REC/PB	PB
Drum speed servo		▶	
Drum phase servo		▶▶	
Drum servo (speed and phase)		▶▶▶	
Capstan speed servo	▶	▶▶	▶▶▶
Capstan servo (speed and phase)	▶▶	▶▶▶	▶▶▶▶

MA-338 (5/9) (DISPLAY) SCHEMATIC DIAGRAM
 — Ref. No. MA-338 Board:1,000 Series —

For schematic diagram
 • Refer to page 4-5 for printed wiring board.
 • Refer to page 4-2 for waveforms.



MA-338 BOARD (5/9)
 DISPLAY CONTROL
 -REF. NO. : 1000 SERIES-
 XX MARK : NO MOUNT

A
B
C
D
E
F
G

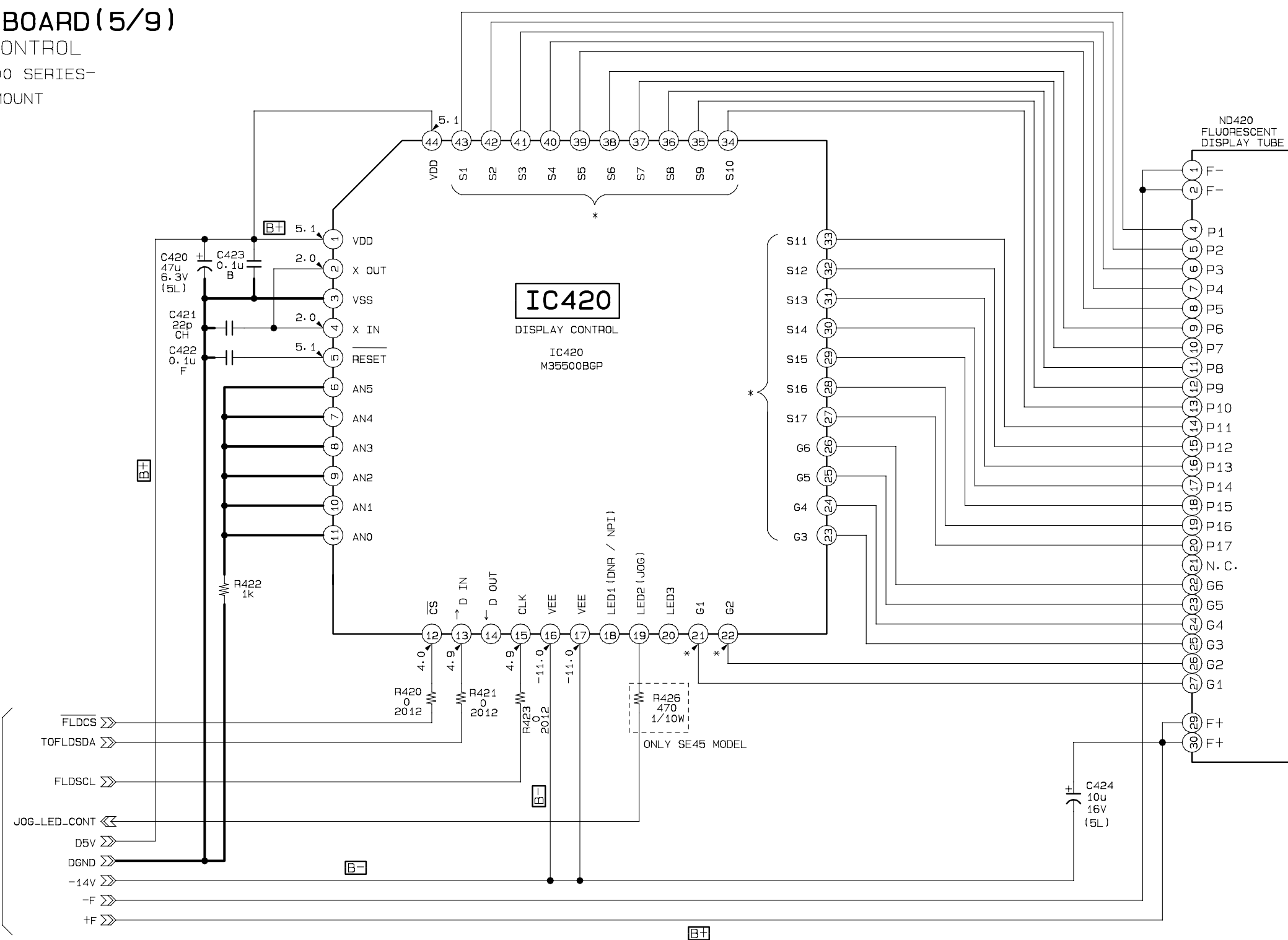

⑩ TO MA-338 BOARD (4/9)
 (SEE PAGE 4-9)

MA-338 (6/9) (INPUT/OUTPUT) SCHEMATIC DIAGRAM

For schematic diagram
• Refer to page 4-5 for printed wiring board.

— Ref. No. MA-338 Board:1,000 Series —

MA-338 BOARD (6/9)

IN/OUT
-REF. NO. : 1000 SERIES-
XX MARK: NO MOUNT
NO MARK: REC/PB MODE
R : REC MODE
P : PB MODE

• SIGNAL PATH

	VIDEO SIGNAL			AUDIO SIGNAL
	CHROMA	Y	Y/CHROMA	
REC	→	→	→	→
PB	→	→	→	→

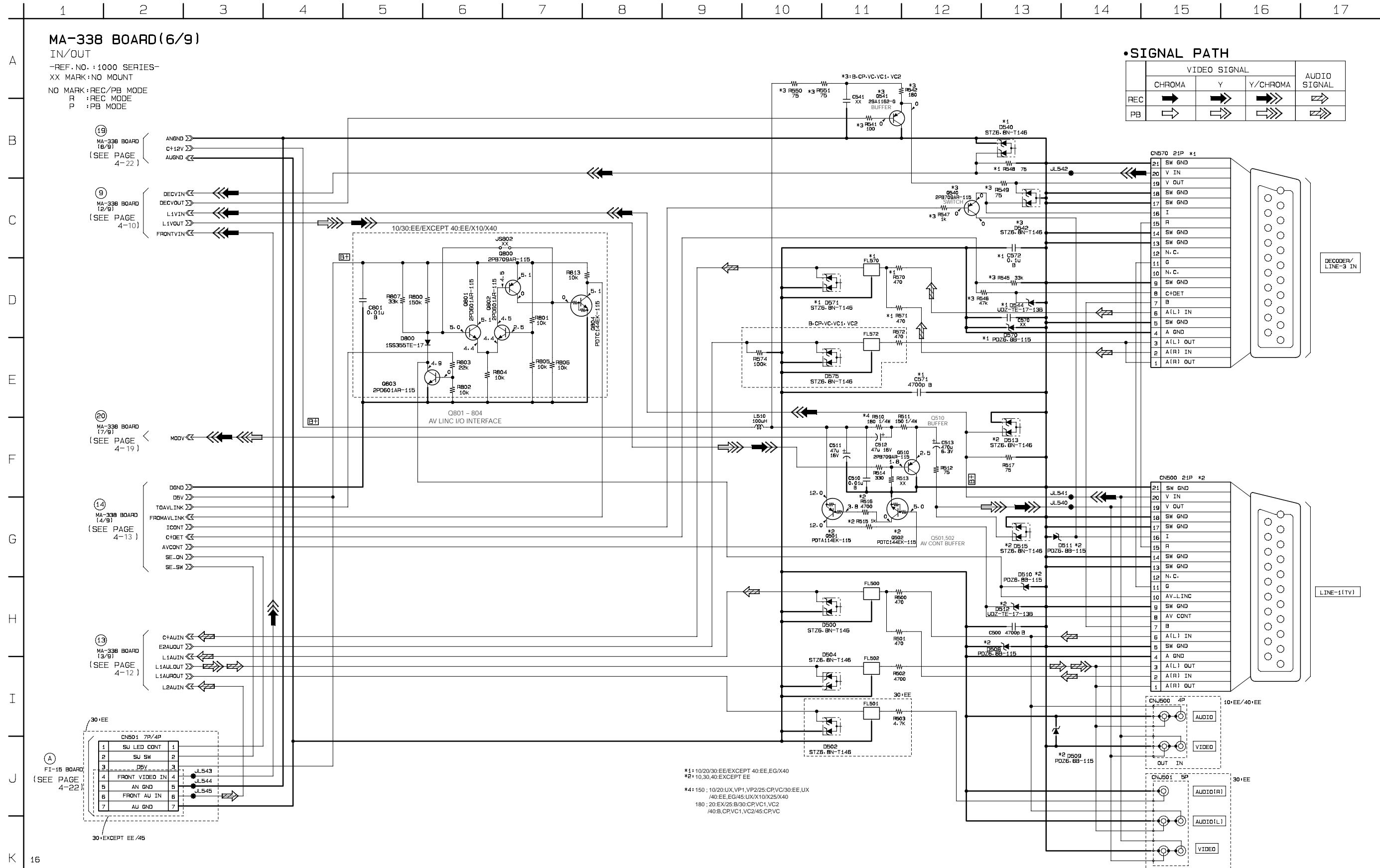

MA-338 (7/9) (TUNER) SCHEMATIC DIAGRAM

For schematic diagram
• Refer to page 4-5 for printed wiring board.

1 2 3 4 5 6 7 8 9 10 11 12 13 14 15 16 17

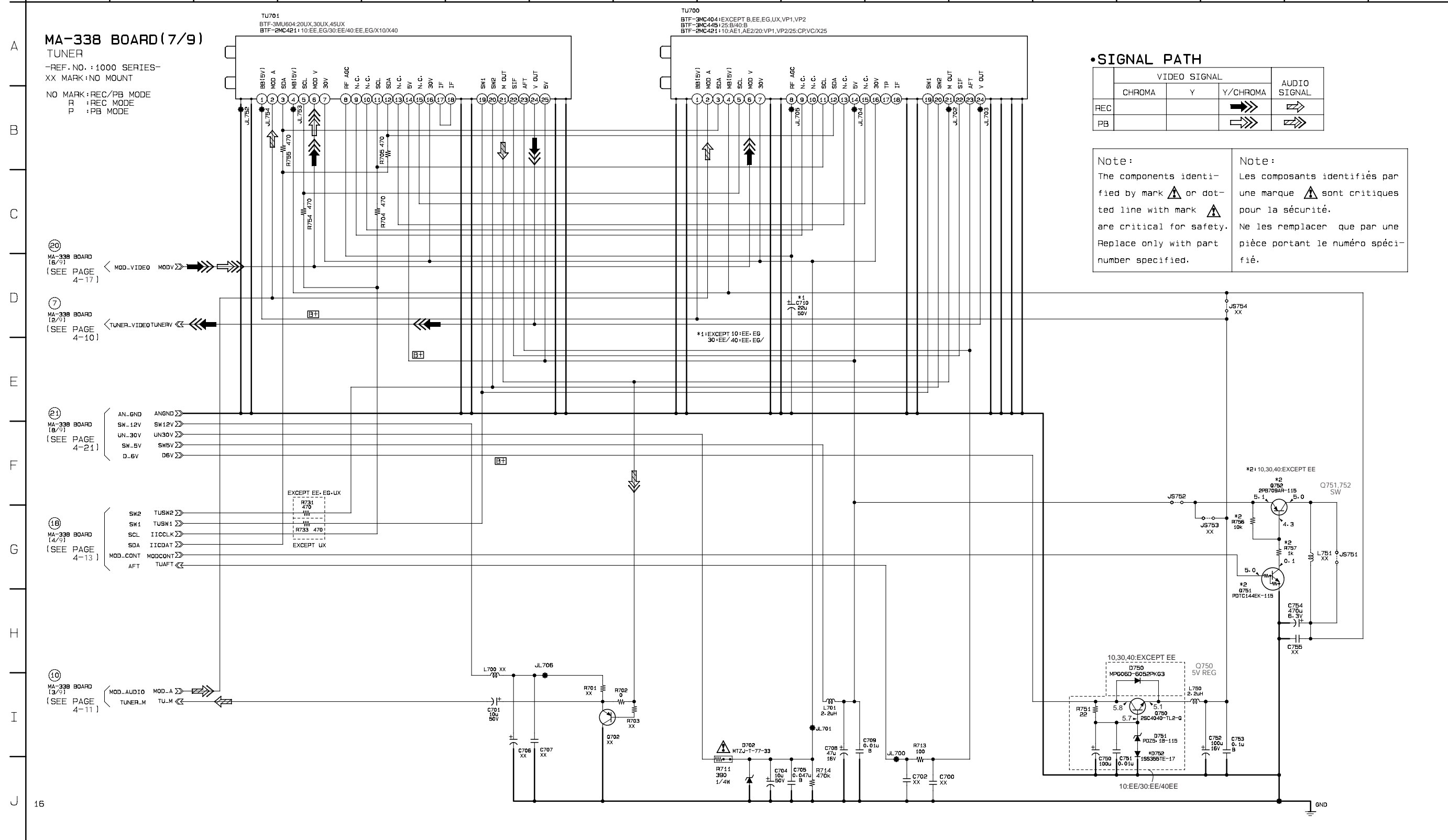

• SIGNAL PATH

	VIDEO SIGNAL			AUDIO SIGNAL
	CHROMA	Y	Y/CHROMA	
REC			➡➡➡	➡➡
PB			➡➡➡	➡➡

Note:
The components identified by mark or dotted line with mark are critical for safety. Replace only with part number specified.

Note:
Les composants identifiés par une marque sont critiques pour la sécurité. Ne les remplacer que par une pièce portant le numéro spécifié.

MA-338 BOARD (7/9)
TUNER
-REF. NO. : 1000 SERIES-
XX MARK: NO MOUNT
NO MARK: REC/PB MODE
R : REC MODE
P : PB MODE

20 MA-338 BOARD (6/9) (SEE PAGE 4-17)

7 MA-338 BOARD (2/9) (SEE PAGE 4-10)

21 MA-338 BOARD (8/9) (SEE PAGE 4-21)

16 MA-338 BOARD (4/9) (SEE PAGE 4-13)

10 MA-338 BOARD (3/9) (SEE PAGE 4-11)

MA-338 (8/9) (POWER SUPPLY) SCHEMATIC DIAGRAM

— Ref. No. MA-338 Board:1,000 Series —

For schematic diagram

• Refer to page 4-5 for printed wiring board.

1 2 3 4 5 6 7 8 9 10 11 12 13

MA-338 BOARD(8/9)

POWER SUPPLY

-REF. NO. : 1000 SERIES-

XX MARK:NO MOUNT

(D) POWER BLOCK (SR701)
(SEE PAGE 4-24)

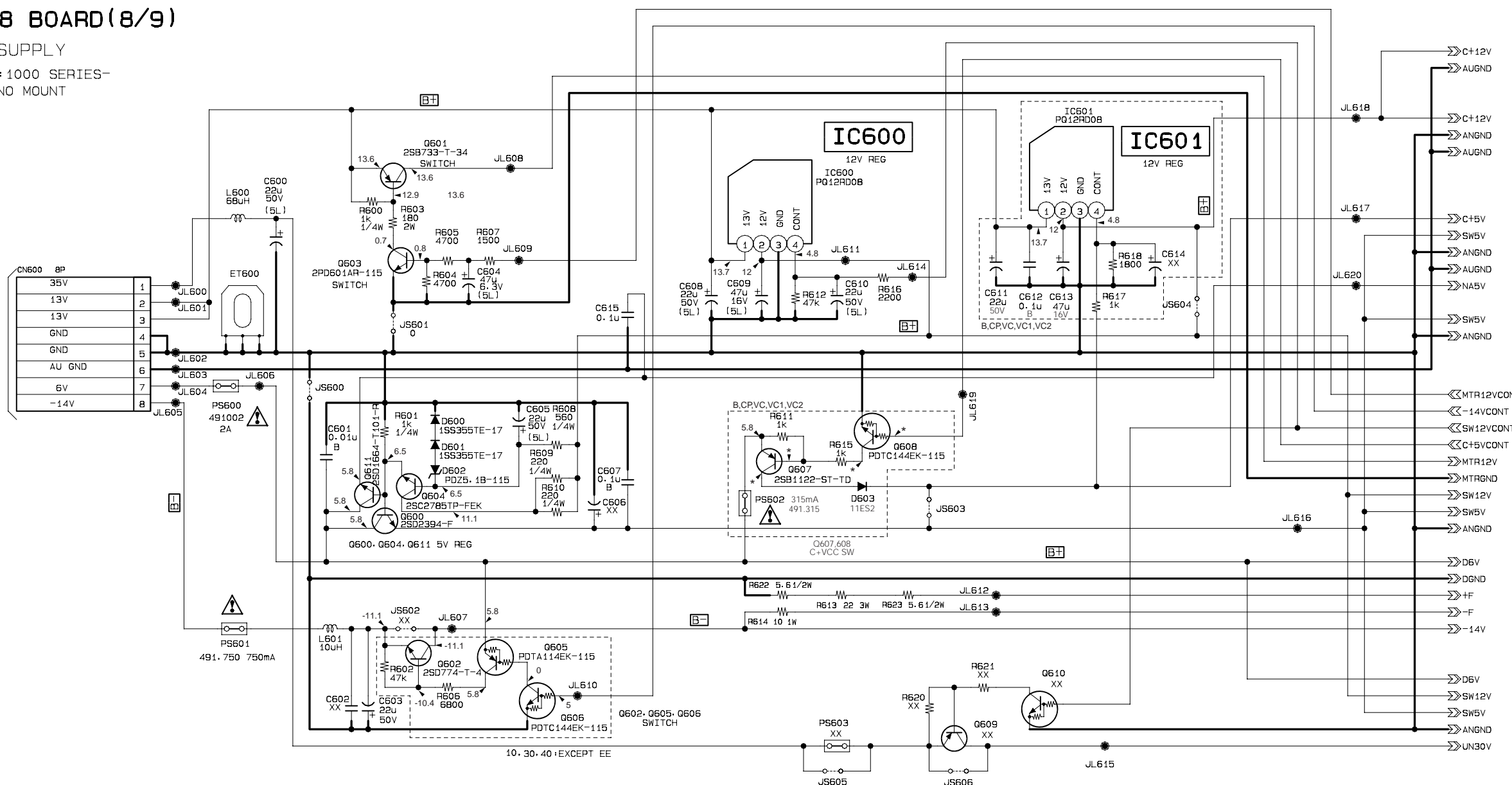

- (12) MA-338 BOARD (3/9) (SEE PAGE 4-11)
- (19) MA-338 BOARD (6/9) (SEE PAGE 4-17)
- (4) MA-338 BOARD (2/9) (SEE PAGE 4-9)
- (3) MA-338 BOARD (1/9) (SEE PAGE 4-8)
- (17) MA-338 BOARD (4/9) (SEE PAGE 4-13)
- (21) MA-338 BOARD (7/9) (SEE PAGE 4-19)

Note:
The components identified by mark or dotted line with mark are critical for safety. Replace only with part number specified.

Note:
Les composants identifiés par une marque sont critiques pour la sécurité. Ne les remplacer que par une pièce portant le numéro spécifié.

MA-338 (9/9) (SECAM VIDEO SIGNAL PROCESSOR) SCHEMATIC DIAGRAM

— Ref. No. MA-338 Board:1,000 Series —

For schematic diagram

• Refer to page 4-5 for printed wiring board.



MA-338 BOARD (9/9) (SE25B, SE40B MODEL)

XX MARK: NO MOUNT
 NO MARK: REC/PB MODE
 R : REC MODE
 P : PB MODE

• SIGNAL PATH

	VIDEO SIGNAL		
	CHROMA	Y	Y/CHROMA
REC	➔		➔➔➔
PB	➔		➔➔➔

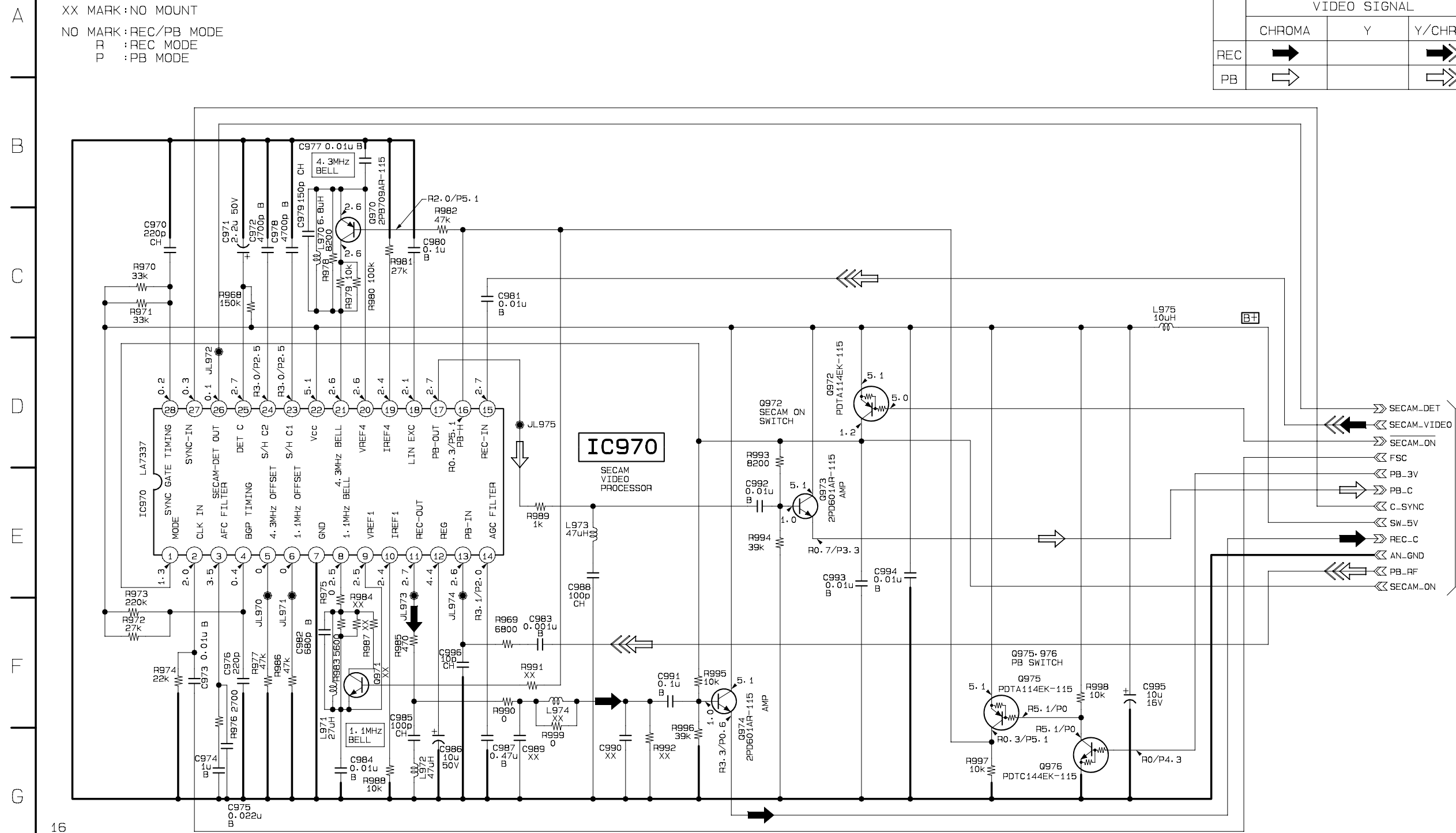

TO/FROM MA-338 BOARD (2/9)
 (SEE PAGE 4-10)

FI-15 (LINE-2 IN) PRINTED WIRING BOARD AND SCHEMATIC DIAGRAM

— Ref. No. FI-15 Board:2,000 Series —

There are few cases that the part printed on this diagram isn't mounted in this model.

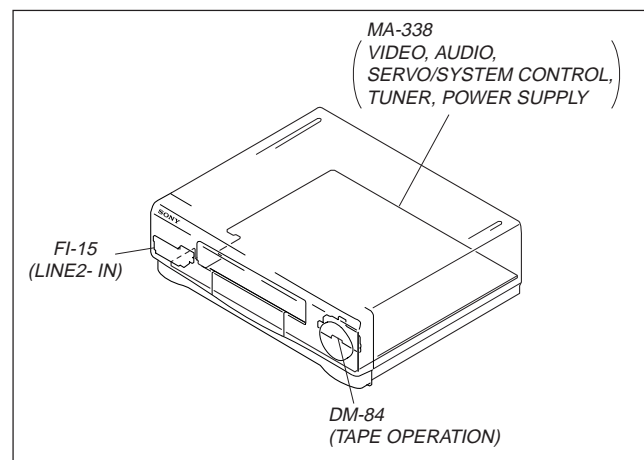
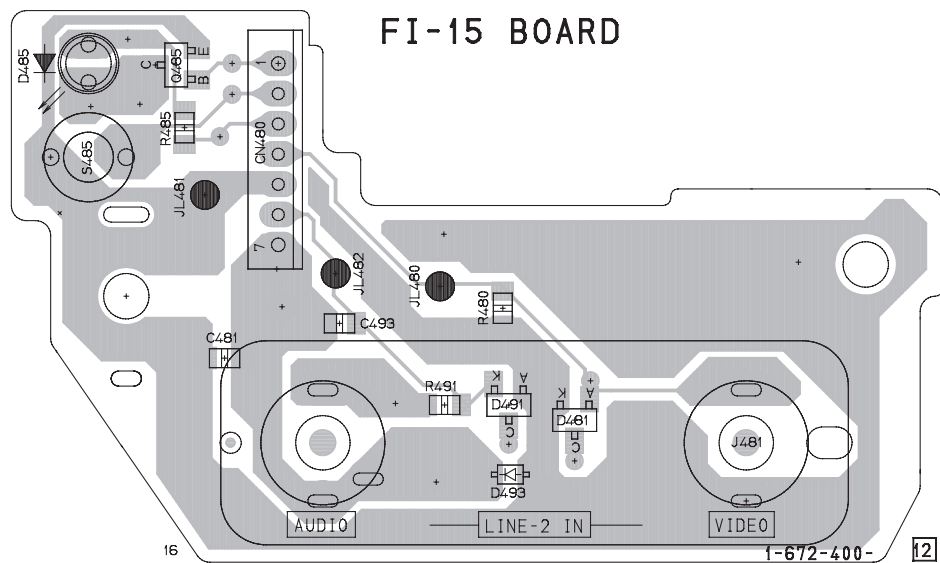

DS-83 (DUAL SHUTTLE) PRINTED WIRING BOARD AND SCHEMATIC DIAGRAM

— Ref. No. DS-83 Board:3,000 Series —

There are few cases that the part printed on this diagram isn't mounted in this model.

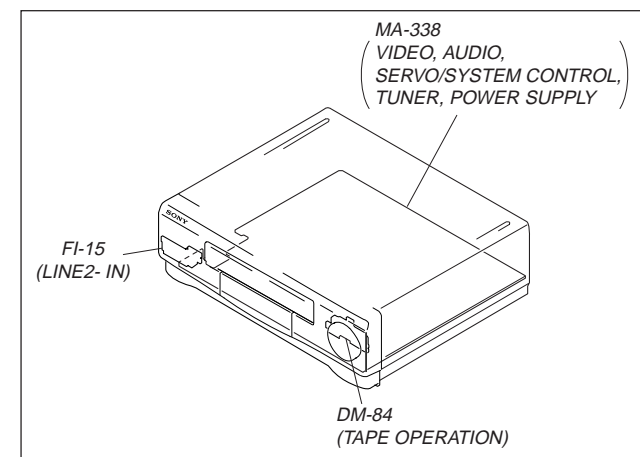
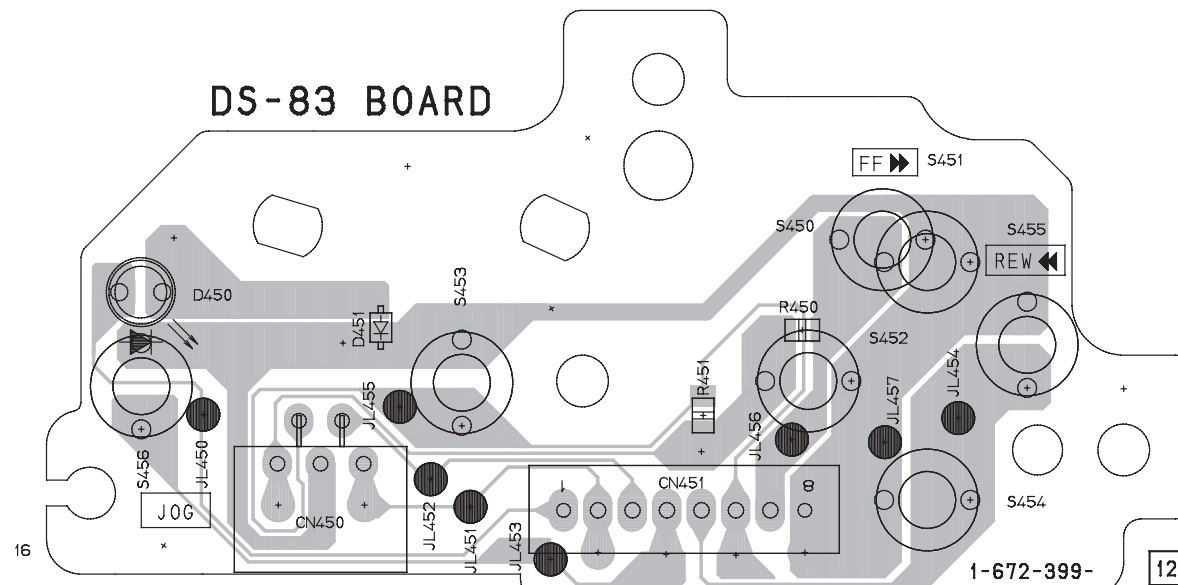

FI-15 BOARD (SE45, SE30 MODEL)

LINE-2 IN
-REF. NO. : 1000 SERIES-

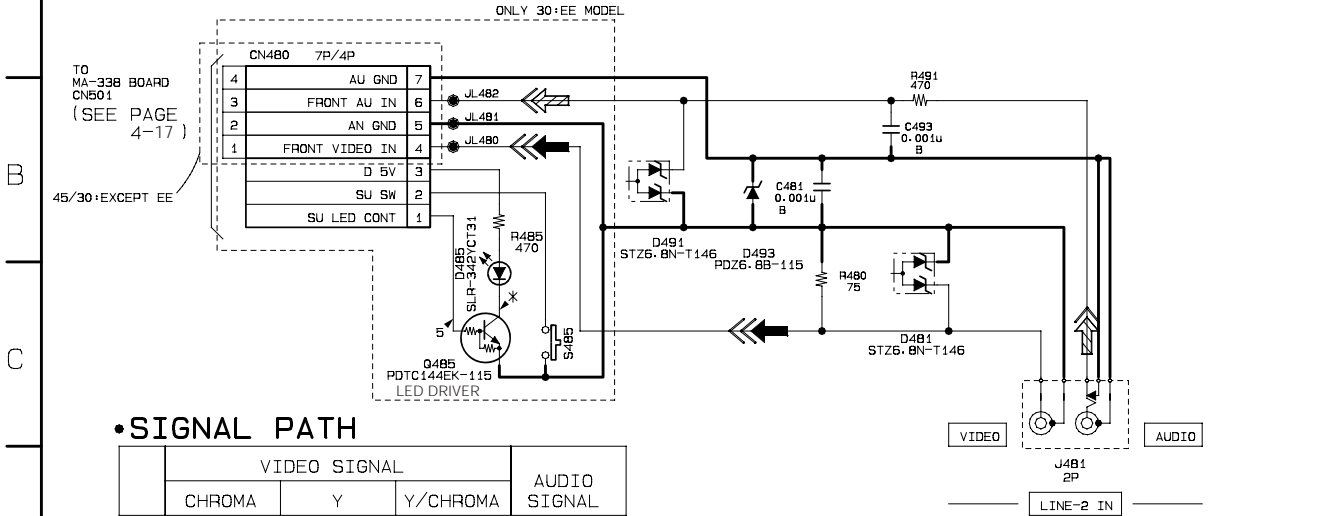

•SIGNAL PATH

	VIDEO SIGNAL			AUDIO SIGNAL
	CHROMA	Y	Y/CHROMA	
REC			➔➔➔	➔➔➔
PB				

DS-83 BOARD

OPERATION SWITCHES
-REF. NO. : 1000 SERIES-

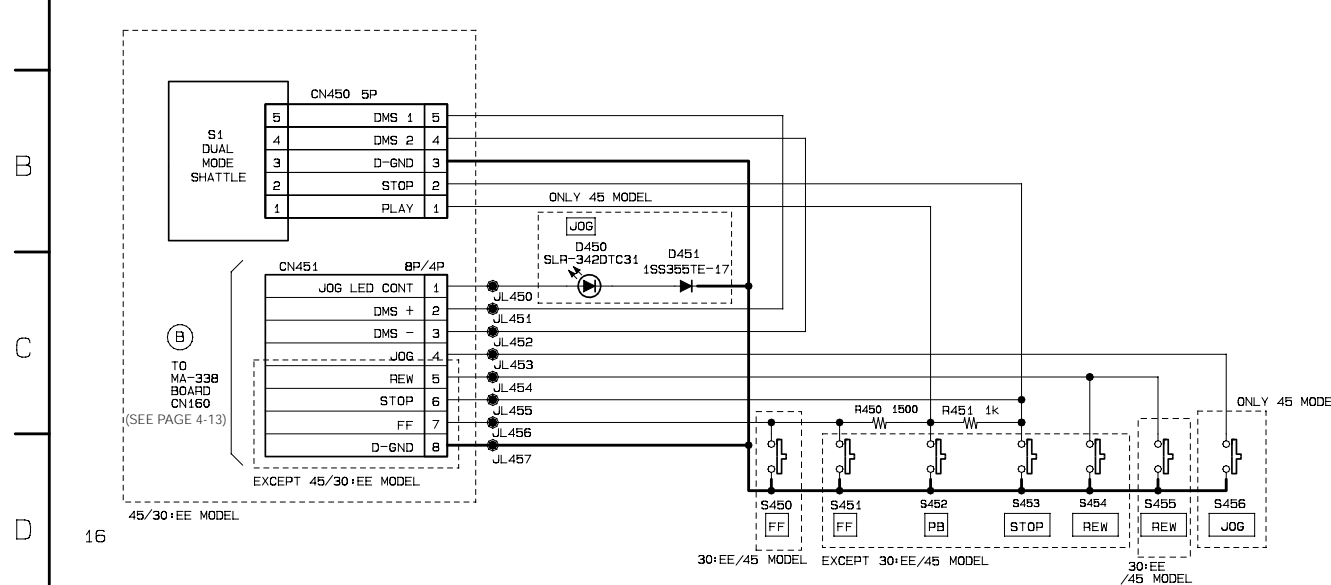

POWER BLOCK ETXNY165E1D (SWITCHING REGULATOR) PRINTED WIRING BOARD AND SCHEMATIC DIAGRAM

— Ref. No. SR701 Board:9,000 Series —

There are few cases that the part printed on this diagram isn't mounted in this model.

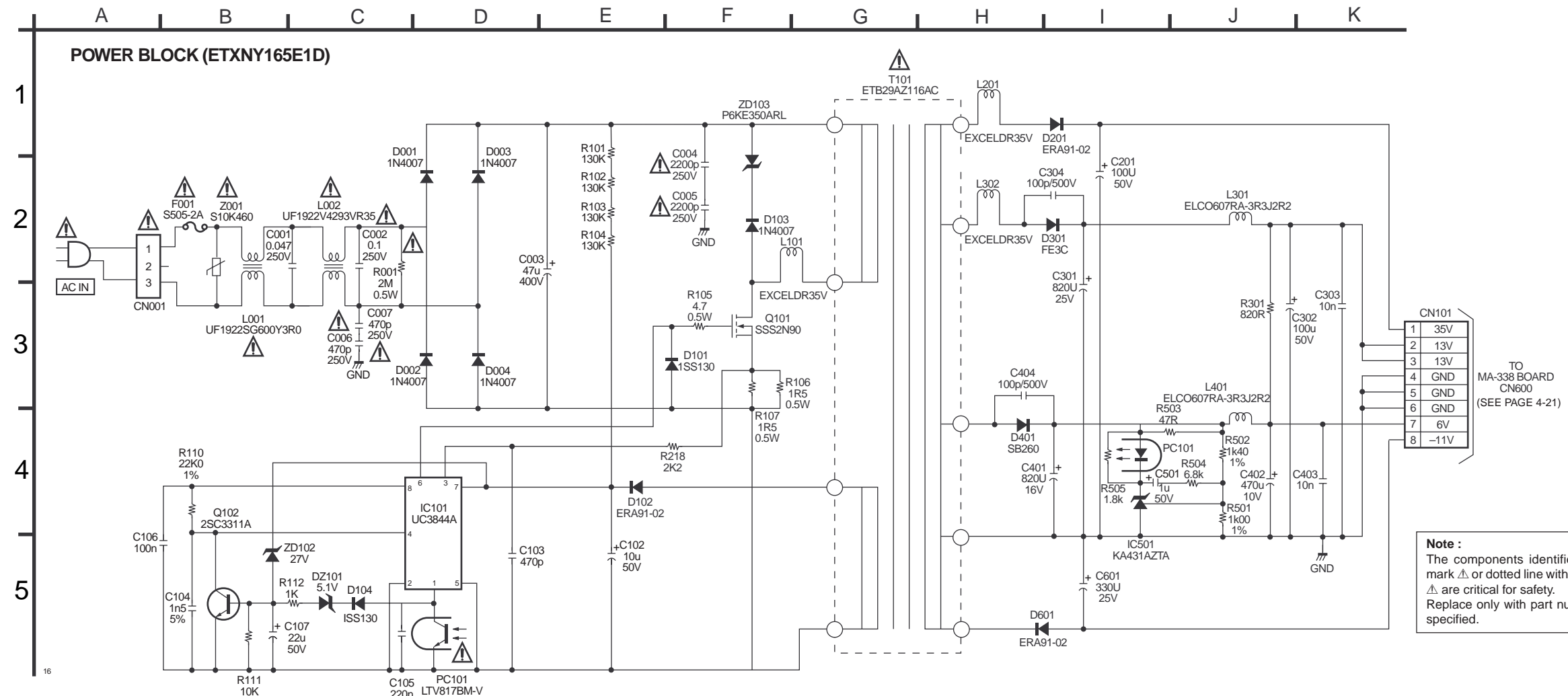
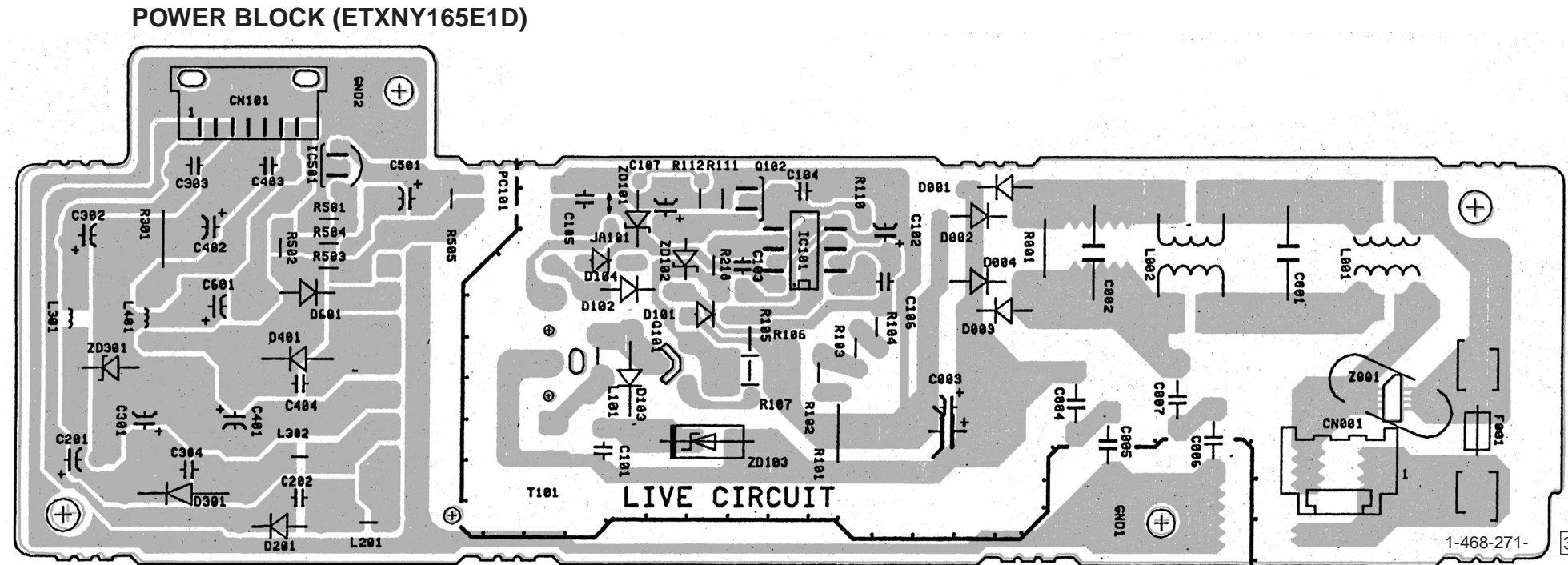

Note :
The components identified by mark Δ or dotted line with mark Δ are critical for safety. Replace only with part number specified.

Note :
Les composants identifiés par une marque Δ sont critiques pour la sécurité. Ne les remplacer que par une pièce portant le numéro spécifié.

5-1. SYSTEM CONTROL — VIDEO/RP BLOCK INTERFACE (MA-338 BOARD IC162)

Signal	Pin No.	I/O	STOP/ FF/REW	TAPE LOADING	TAPE UNLOADING	PB	REC	REC/PAUSE
RF SWP	MA-338 IC162 ①	O	*1	*1	*1	*1	*1	*1
QVD	MA-338 IC162 ②	O	L	L	L	*2	L	L
C SYNC	MA-338 IC162 ③	I	*3	*3	*3	*3	*3	*3

- *1 Synchronized with drum rotation. 25 Hz 50% duty pluse.
- *2 Normally "L". "H" when video signal is not generated.
- *3 Composite sync signal (positive).

5-2. SYSTEM CONTROL — SERVO PERIPHERAL CIRCUIT INTERFACE (MA-338 BOARD IC162)

Signal	Pin No.	I/O	STOP	FF	REW	TAPE LOADING	TAPE UNLOADING	PB	REC
CTL IN (+)	MA-338 IC162 ④	O	*7	*7	*7	*7	*7	*7	*1
DRM PG	MA-338 IC162 ⑤	I	*3	*3	*3	*3	*3	*3	*3
DRM FG	MA-338 IC162 ⑥	I	*4	*4	*4	*4	*4	*4	*4
CAP FG	MA-338 IC162 ⑦	I	H/L	*2	*2	*5	*5	*2	*2
CAP RVS	MA-338 IC162 ⑧	O	H/L	L	H	L	H	L	L
CAP ERR	MA-338 IC162 ⑨	O	L	*6	*6	*6	*6	*6	*6
DRM ERR	MA-338 IC162 ⑩	O	*6	*6	*6	*6	*6	*6	*6

- *1. 25 Hz pulse.
- *2. Pulse in period in proportion to tape speed.
- *3. 25 Hz "H" pulse.
- *4. 330 Hz pulse.
- *5. Unstable period pulse.
- *6. DC voltage 1 to 5V.
- *7. Hi-Z (2.5 V)

5-3. SYSTEM CONTROL — MECHANISM BLOCK INTERFACE (MA-338 BOARD IC162)

Signal	Pin No.	I/O	EJECTED	CASSETTE LOADING	CASSETTE UNLOADING	TAPE THREADING	TAPE UNTHREADING	STOP	FF	REW	PB	REC
CAM	MA-338 IC162 ㉓	O	M	H/M	L/M	H/M	L/M	M	M	M	M	M
MODE 1	MA-338 IC162 ㉔	I	H	—	—	L	L	H	H	H	H	H
MODE 2	MA-338 IC162 ㉕	I	H	—	—	L	L	H	H	H	L	L
MODE 3	MA-338 IC162 ㉖	I	L	—	—	H	H	H	L	L	L	L
MODE 4	MA-338 IC162 ㉗	I	L	—	—	H	H	L	H	H	L	L
REC PRF	MA-338 IC162 ㉘	I	L	*1	*1	*1	*1	*1	*1	*1	*1	*1
T REEL	MA-338 IC162 ㉙	I	H/L	H/L	H/L	H/L	H/L	H/L	*2	*2	*2	*2
S REEL	MA-338 IC162 ㉚	I	H/L	H/L	H/L	*2	*2	H/L	*2	*2	*2	*2
END LED	MA-338 IC162 ㉛	O	L	*3	*3	*3	*3	*3	*3	*3	*3	*3
T SENS	MA-338 IC162 ㉜	I	*3	*3	*3	*4	*4	*4	*4	*4	*4	*4
S SENS	MA-338 IC162 ㉝	I	*3	*3	*3	*4	*4	*4	*4	*4	*4	*4

- *1. "L" when erasing protection tab is bent. "H" when not bent.
- *2. Pulse of period in proportion to reel rotating speed.
- *3. Approx. 2 msec period "H" pulse.
- *4. Normally "L". 2 msec period "H" pulse when tape top or tape end is detected.
- *5. Hi-Z

5-4. SYSTEM CONTROL — SYSTEM CONTROL PERIPHERAL CIRCUIT INTERFACE (MA-338 BOARD IC162)

Signal	Pin No.	I/O	I/O level
RESET	MA-338 IC162 ㉞	I	Normal "H", "L" when seryvice Interruption is detected or restored.

5-5. SYSTEM CONTROL — AUDIO BLOCK INTERFACE (MA-338 BOARD IC162)

Signal	Pin No.	I/O	STOP/ FF/REW	TAPE LOADING	TAPE UNLOADING	PB	REC	REC/PAUSE
A MUTE	MA-338 IC162 ㉟	O	L	L	L	L	L	H

5-6. SERVO/SYSTEM CONTROL MICROPROCESSOR PIN FUNCTIONS (MA-338 BOARD IC162)

Pin No.	Pin Name	I/O	Function
1	DEST1	I	Destination identification input 1
2	DEST2	I	Destination identification input 2
3	TU AFT	I/O	AFT input to TUNER for station selection
4	FU KEY2	I	Function key input (9 keys)
5	FU KEY1	I	Function key input (9 keys)
6	S SENS	I	Tape end sensor input
7	T SENS	I	Tape top sensor input
8	RF ENV	I/O	Video RF envelop input
9	N.C.	—	N.C.
10	MOD CONT	O	RF modulator ON/OFF control
11	KKP+	I	KKP 2-phase pulse B input
12	KKP-	I	KKP 2-phase pulse A input
13	Q VD	O	Pseudo VD output
14	REMOCON	I	Remote control SIRCS signal input
15	COLOR ROT	O	Head azimuth information
16	HA SW P	O	SP/EP head switching signal
17	ENV SW	I	Identification signal of SP/EP head output comparison & detection
18	RF SW P	I/O	Video RF switching pulse output
19	N.C.	—	N.C.
20	END LED	O	End sensor LED output
21	AV CONT	O	EURO 21 pin AV CONT signal output
22	AF REC P	O	HiFi record control signal
23	FULL ERS	I/O	Full erase control signal for A DUB
24	CAP RVS	O	Inverted capstan signal
25	I CONT	O	EURO 21 pin-1 CONT signal output
26	MODE 4	I	Cam encode data 4
27	MODE 3	I	Cam encode data 3
28	MODE 2	I	Cam encode data 2
29	MODE 1	I	Cam encode data 1
30	REC PRF	I	Safety tab detection input
31	I2C CLK EEP	O	I2C clock (EEPROM control)
32	I2C DATA EEP	I/O	I2C data (EEPROM control)
33	CAM	O	Cam motor control signal
34	RESET	I	Reset input
35	Xc IN (32kHz)	I	Sub clock input
36	Xc OUT (32kHz)	O	Sub clock output
37	Vcc		Power supply input terminal (high speed mode: 4.0 to 5.5 V, low speed mode: 2.6 to 5.5 V)
38	X IN (17.734475MHz)	I	Main clock input
39	X OUT (17.734475MHz)	O	Main clock output
40	Vss		Ground terminal
41	N.C.	—	N.C.
42	N.C.	—	N.C.
43	CLK SEL	I	Selection of oscillation clock when reset is canceled. L: sub clock, H: main & sub clocks
44	OSC IN	I/O	Clock input for OSD character size
45	OSC OUT	I/O	Clock output for OSD character size
46	NUB		Connected to Ground
47	OSD LPF	I/O	External filter that doubles the fsc, is connected to this terminal
48	LP	O	L at SP
49	OSD GND		Ground terminal of OSD/slicer
50	OSD V IN	I	Video signal input for OSD overlay

Pin No.	Pin Name	I/O	Function
51	OSD W LEVEL	I	OSD white level input
52	OSD V OUT	O	OSD video signal output
53	OSD Vcc		Power supply input terminal for OSD/slicer (4.75 V to 5.25 V)
54	HLF	I/O	LPF connection terminal for slicer/AFC (This terminal is used as the HLF terminal when C. Video is input to pin-56.)
55	OSD SECAM C IN	I	Color signal input for SECAM OSD
56	C. VIDEO IN	I	Video signal input for tuner's station selection, OSD and servo sync signal detection (after passing filter)
57	NUA		Connected to Ground
58	DEC/VTR	O	Decoder/VTR switching
59	PDC DAV	I	PDC/VPS signal reception identification input
60	SECAM DET	I	SECAM identification input
61	DNR RESET	O	DNR IC reset signal
62	TA MUTE	O	Tuner audio mute signal output
63	A MUTE	O	Audio mute signal output
64	MTR 12V CONT.	O	Motor 12 V power control signal
65	SW 12V CONT.	O	SW 12 V power control signal
66	FLD CS	O	Chip selection signal for display tube driver
67	SECAM ON/SUR ON	O	SECAM ON signal/surround audio control (switched by destination)
68	FLD OUT	O	Serial data out CH0 (FLD)
69	FLD IN	I	Serial data in CH0 (FLD)
70	FLD CLK	O	Serial clock CH0 (FLD)
71	SCL	I/O	I2C clock (video/HiFi/tuner/ARC/modulator/VPS/DNR control)
72	SDA	I/O	I2C data (video/HiFi/tuner/ARC/modulator/VPS/DNR control)
73	AV-LINK OUT	O	AV-LINK data output for communication
74	-14V CONT	O	Power save control (equivalent of pin-98 save CONT 1)
75	C+ 5V CONT	O	Power save control (equivalent of pin-98 save CONT C+)
76	CAP ERROR	O	Capstan error output
77	DRUM ERROR	O	Drum error output
78	P FAIL	I	Power failure detection input
79	S REEL	I	Supply reel sensor input
80	T REEL	I	Tape up reel sensor input
81	DMS+	I	DMS 2-phase pulse 1 input
82	DMS-	I	DMS 2-phase pulse 2 input
83	TU SW1	O	Turner system BG/L selection signal
84	TU SW2	O	Turner system BGL/L selection signal
85	AV-LINK IN	I	Data input for AV-LINK communication
86	C+ DET	I	CANAL + connection identification input
87	CAP FG	I	Capstan FG input
88	AMP Vss		Ground terminal for analog amplifier (connected to Vss)
89	DRUM FG	I	Drum FG input
90	DRUM PG	I	Drum PG input
91	AMP VREF OUT		Analog amplifier reference power supply output terminal
92	AMP VREF IN		Analog amplifier reference power supply output terminal
93	RC CHECK	I	Input for RC setting
94	CTL -IN	I/O	CTL signal input/output terminal
95	CTL +IN	I/O	CTL signal input/output terminal
96	AMP C		CTL amplifier AC Ground terminal
97	CTL AMP OUT	O	CTL amplifier output
98	AMP Vcc		Power supply input terminal for analog amplifier (connected to Vcc)
99	AVcc		Power supply input and reference voltage input to A-D converter
100	AUTO PRESET	O	H at Auto preset

5-7. MODE CONTROL PIN FUNCTIONS (MA-338 BOARD IC420)

Pin No.	Pin Name	I/O	Function
1	VDD		D5V
2	X OUT	O	X' tal out
3	VSS		Ground.
4	X IN	I	X' tal in
5	$\overline{\text{RESET}}$	I	RESET input.
6	AN5		Ground.
7	AN4		Ground.
8	AN3		Ground.
9	AN2		Ground.
10	AN1		Ground.
11	AN0		Ground.
12	$\overline{\text{CS}}$	O	FLD chip select signal out.
13	D IN	I	FLD IIC BUS (data) input.
14	D OUT	O	Not connect.
15	CLK	O	FLD clock.
16	VEE		-14V
17	VEE		-14V
18	LED1	O	LED control signal input.
19	LED2	O	JOG LED control signal output.
20	NC		Not Connect.
21	G1	O	Grid terminal 1.
22	G2	O	Grid terminal 2.
23	G3	O	Grid terminal 3.
24	G4	O	Grid terminal 4.
25	G5	O	Grid terminal 5.
26	G6	O	Grid terminal 6.
27	S17	O	Segment terminal 17.
28	S16	O	Segment terminal 16.
29	S15	O	Segment terminal 15.
30	S14	O	Segment terminal 14.
31	S13	O	Segment terminal 13.
32	S12	O	Segment terminal 12.
33	S11	O	Segment terminal 11.
34	S10	O	Segment terminal 10.
35	S9	O	Segment terminal 9.
36	S8	O	Segment terminal 8.
37	S7	O	Segment terminal 7.
38	S6	O	Segment terminal 6.
39	S5	O	Segment terminal 5.
40	S4	O	Segment terminal 4.
41	S3	O	Segment terminal 3.
42	S2	O	Segment terminal 2.
43	S1	O	Segment terminal 1.
44	VDD		D5V

SECTION 6 ADJUSTMENTS

6-1 MECHANICAL ADJUSTMENTS

For the mechanical adjustments, please refer to the "VHS MECHANICAL ADJUSTMENT MANUAL VI (S MECHANISM)" (9-921-647-11).

6-2. ELECTRICAL ADJUSTMENTS

See the adjusting part location diagram from on page 6-6 for the adjustment.

2-1. PREPARATION BEFORE ADJUSTMENT

2-1-1. Equipment Required

The measuring instruments used for this alignment include:

- 1) Monitor TV
- 2) Oscilloscope, dual-trace, bandwidth of 30 MHz or more, with delay mode (A probe 10:1 should be used unless otherwise specified.)
- 3) Frequency counter
- 4) PAL Pattern generator
- 5) Remote commander
- 6) Digital voltmeter
- 7) Audio generator
- 8) Audio level meter
- 9) Audio attenuator
- 10) Alignment tapes
KRV-51P (PAL) Part No. : 8-192-955-57

2-1-2. Equipment Connection

Unless otherwise specified, connect and adjust the measuring instruments as shown in the following diagram.

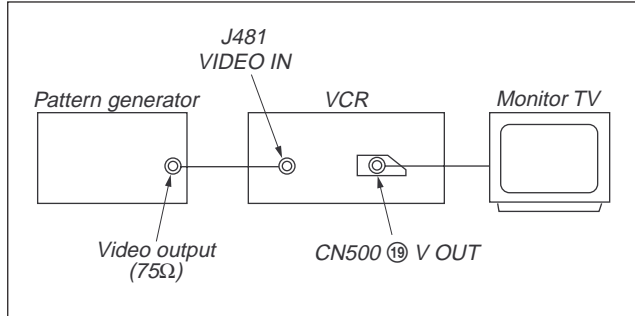

Fig. 6-2-1

2-1-3. Set-up of Adjustment

In this adjustment, PAL pattern generator is connected with LINE-2 input terminal. When check to tuner, connected AERIAL terminal. Check that the synchronizing signal of the Y signal has an amplitude of approximately 0.7 V and that the waveform is flat. And check that the level ratio of burst signal to "red" signal is 0.30 : 0.66. The video signal (color bar) used for electrical aligning this unit is shown in Fig. 6-2-2.

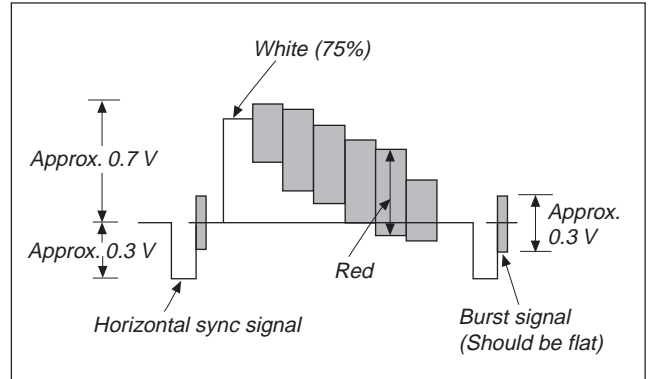

Fig. 6-2-2 Color Bar Signals of Pattern Generator

2-1-4. Alignment Tape

• Contents of KRV-51P

	Mode	Period	Video signal	Audio signal	
				Hi-Fi	Normal
1	SP	7 minutes	Color bar	400Hz (L/R)	400Hz
2		3 minutes	Monoscope		
3	LP	7 minutes	Color bar		
4		3 minutes	Monoscope		

2-1-5. Input/Output Levels and Impedance

Video input: LINE-1 (TV)/LINE-2 IN/LINE-3 IN

Input signal: 1 V_{p-p}, 75 ohms, unbalanced, sync negative

Video output: LINE-1 (TV)

Output signal: 1 V_{p-p}, 75 ohms, unbalanced, sync negative

Audio input: LINE-1 (TV)/LINE-2 IN/LINE-3 IN

Input level: -7.5 dBs
(0 dBs= 0.775 V_{rms})

Input impedance: more than 47 kilohms

Audio output: LINE-1 (TV)

Standard level: -7.5 dBs at load impedance 47 kilohms

Output impedance: less than 10 kilohms

2-1-6. Adjustment Sequence

The adjustments should be performed in the following sequence.

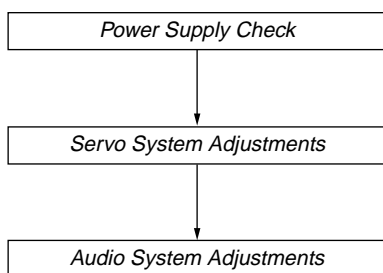

2-2. POWER SUPPLY CHECK

2-2-1. Output Voltage Check (MA-338 Board)

Mode	STANDBY
+30 V Check	
Measurement point	CN600 pin ①
Specified value	31.0 to 39.0 V
Mode	E-E
+6 V Check	
Measurement point	Corrector of Q600
Specified value	5.56 to 6.25 V

-11 V Check	
Measurement point	Corrector of Q602
Specified value	-13.5 to -9.5 V
+12 V Check	
Measurement point	IC600 pin ②
Specified value	11.7 to 12.3 V
+5 V Check	
Measurement point	Emitter of Q600
Specified value	4.8 to 5.4 V
MTR12 V Check	
Measurement point	Corrector of Q601
Specified value	12.6 to 14.6 V

[Check Method]

- 1) Each of these supply voltages must meet its specified value.

2-3. SERVO SYSTEM CHECK

2-3-1. RF Switching Position Adjustment (MA-338 Board)

[Adjustment Purpose]

To adjust the link of the A-ch and B-ch of the tape playback outputs. To make the unit compatible with other tapes and units. If this specification is not satisfied, the link will appear on the screen and the screen will be disrupted, etc.

Mode	Playback
Signal	Alignment tape: SP color bar portion
Measurement point	CH1: CN262 pin ① (PB RF) CH2: CN262 pin ② (RF SWP)
Measuring instrument	Oscilloscope
Adjusting element	Remote commander CH+/-
Specified value	A=minimize

[Adjustment Method]

- 1) Playback the alignment tape.
- 2) Short CN262 pin ⑤ to Ground.
- 3) Check that "A P" is indicated on FL display.
- 4) Adjust so that part A becomes minimized at CH +/-.
- 5) Write data in EEPROM by pressing PAUSE button.
- 6) The display "A P" disappears and then the Adjustment mode terminates.

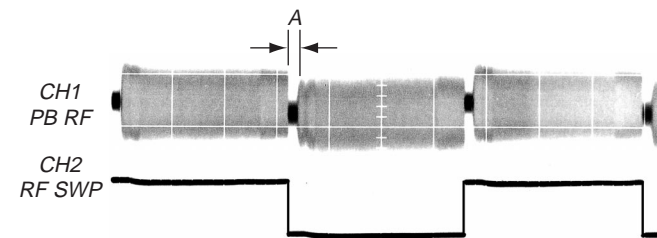

Fig. 6-2-3

2-4. AUDIO SYSTEM ADJUSTMENT

[Connecting Instruments]

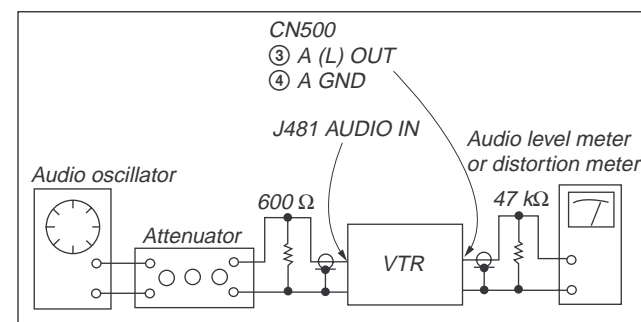

Fig. 6-2-3

2-4-1. Normal Audio System Adjustment

- Make adjustment in the SP mode unless otherwise specified. Use a normal VHS cassette for an adjustment tape.
- Set AUDIO MONITOR to normal.

2-4-2. ACE Head Adjustment

Refer to the VHS mechanical adjustment manual VI (S MECHANISM) (9-921-647-11).

2-4-3. E-E Output Level Check

[Adjustment purpose]

Confirm that the output level adjust the reference input is within the specification.

Mode	E-E
Signal	400 Hz, -6.3 dBs
Measurement point	CN500 Pin ③
Measuring instrument	Audio level meter
Specified value	-6.3 ± 2 dBs

[Check Method]

- 1) Input signal of 400 Hz and -6.3 dBs to the J480.
- 2) Check that the audio output level is -6.3 ± 2 dBs.

2-4-4. Frequency Response Check

[Adjustment purpose]

Confirm that the frequency characteristic is within the specification.

Mode	REC and PB (SP mode)
Signal	400 Hz, -26.3 dBs 4 kHz, -26.3 dBs
Measurement point	CN500 Pin ③
Measuring instrument	Audio level meter
Specified value	-6 dB to +4 dB

Note: Tape path adjustment must have been completed.

[Confirmation Method]

- 1) Supply a signal of 400 Hz, -26.3 dBs to J481 AUDIO IN.
- 2) Connect the audio level meter to CN500 Pin ③.
- 3) Adjust the attenuator so that the audio level meter will indicate -26.3 dBs.
- 4) Make recording in the SP mode.
- 5) Set an audio line input signal to 4 kHz and make recording.
- 6) Playback a recorded portion, and measure output levels at 400 Hz and 4 kHz.
- 7) Confirm that the 4 kHz playback output level within a range of the 400 Hz playback output level -6 dB to +4 dB.

2-5. ADJUSTING PARTS LOCATION DIAGRAM

MA-338 BOARD (CONDUCTOR SIDE)

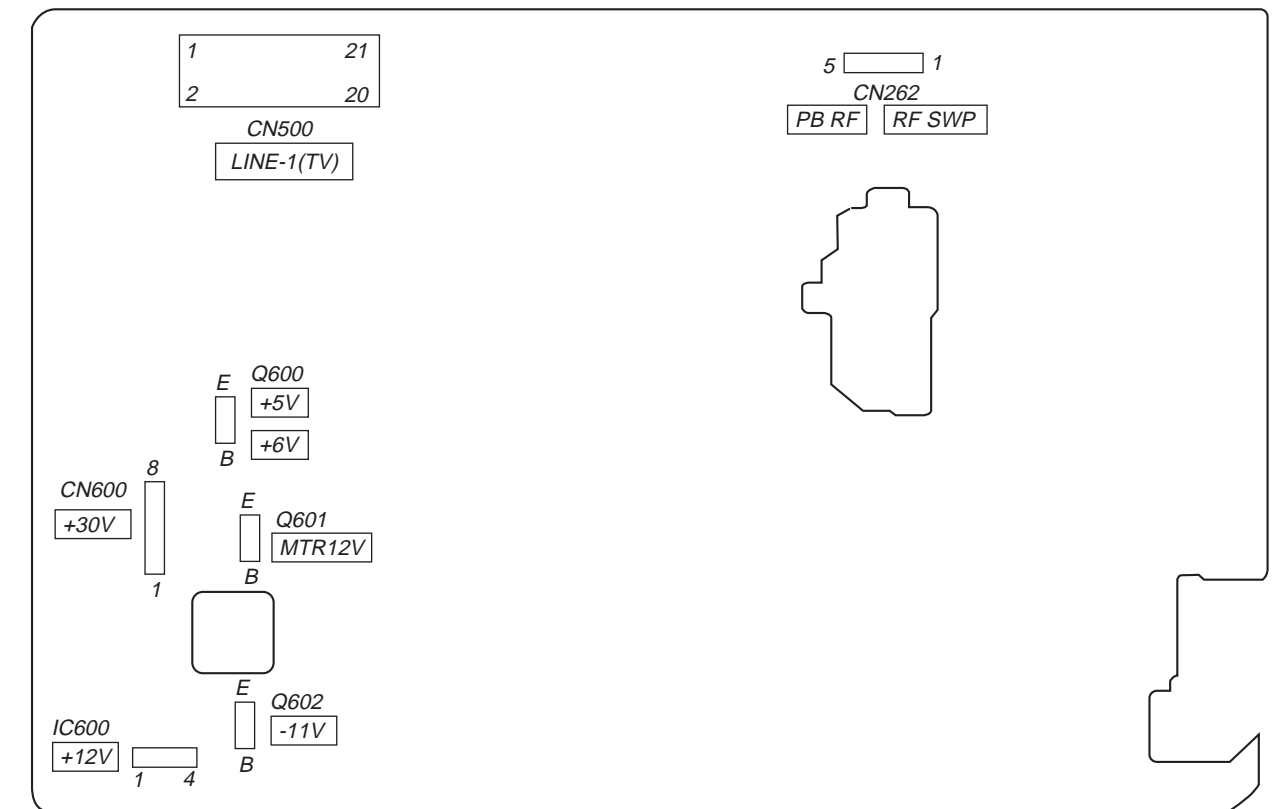

FI-15 BOARD (CONDUCTOR SIDE)

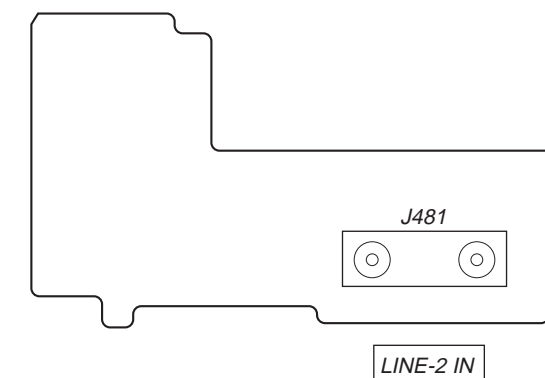

**SECTION 7
REPAIR PARTS LIST**

7-1. EXPLODED VIEWS

NOTE:

- -XX, -X mean standardized parts, so they may have some differences from the original one.
- Items marked “*” are not stocked since they are seldom required for routine service. Some delay should be anticipated when ordering these items.
- The mechanical parts with no reference number in the exploded views are not supplied.

- Hardware (# mark) list and accessories and packing materials are given in the last of this parts list.
- Abbreviation
X10 : SX10
X25 : SX25
X40 : SX40

The components identified by mark Δ or dotted line with mark Δ are critical for safety. Replace only with part number specified.

Les composants identifiés par une marque Δ sont critiques pour la sécurité. Ne les remplacer que par une pièce portant le numéro spécifié.

7-1-1. FRONT PANEL AND UPPER CASE SECTION

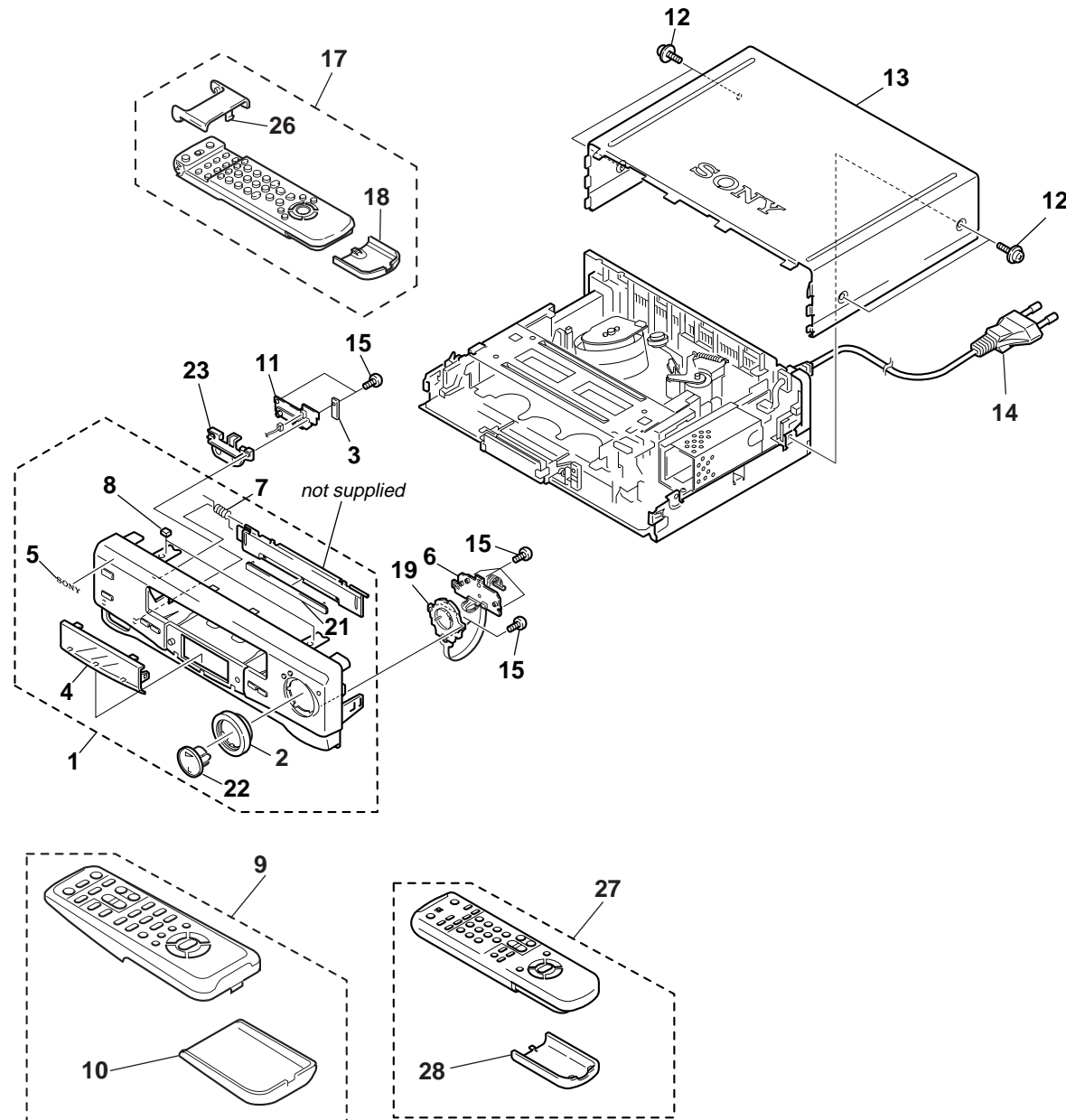

Ref. No.	Part No.	Description	Remarks	Ref. No.	Part No.	Description	Remarks
1	X-3949-237-1	PANEL ASSY, FRONT (45:UX)		* 11	A-6794-662-A	FI-15A BOARD, COMPLETE (30:EE)	
1	X-3949-238-1	PANEL ASSY, FRONT (45:VC)		12	3-710-901-11	SCREW (TP3 x 8), CASE	
1	X-3949-239-1	PANEL ASSY, FRONT (45:CP)		13	3-979-384-21	CASE(E), UPPER (EXCEPT EX,UX,X10,X25,X40)	
1	X-3949-240-1	PANEL ASSY, FRONT (40:VC1,VC2)		13	3-979-384-61	CASE(E), UPPER (EX,UX,X10,X25,X40)	
1	X-3949-241-1	PANEL ASSY, FRONT (40:B)		Δ 14	1-777-854-21	CORD, POWER	
1	X-3949-242-1	PANEL ASSY, FRONT (40:CP)		15	4-921-277-41	SCREW (B2.6 x 8), TAPPING, BIND	
1	X-3949-243-1	PANEL ASSY, FRONT (30:UX)		17	1-418-010-11	COMMANDER, STANDARD (RMT-V259) (30:CP,UX,VC2,VC1/45)	
1	X-3949-244-1	PANEL ASSY, FRONT (30:VC1,VC2)		18	3-709-431-01	COVER, REMOTE CONTROL BATTERY (30:CP,UX,VC2,VC1/45)	
1	X-3949-245-1	PANEL ASSY, FRONT (30:CP)		19	1-762-844-21	SWITCH, ROTARY (30:EE/45)	
1	X-3949-246-1	PANEL ASSY, FRONT (X25)		21	3-053-419-01	ESCUICHEON, CASSETTE (40:CP,EE,EG,VC2,VC1/X40/45)	
1	X-3949-247-1	PANEL ASSY, FRONT (25:VC)		21	3-053-419-11	ESCUICHEON, CASSETTE (40:B)	
1	X-3949-248-1	PANEL ASSY, FRONT (25:B)		21	3-053-419-21	ESCUICHEON, CASSETTE (10:AE1,AE2/20/25:CP,VC,X25/30:UX,CP,VC1,VC2)	
1	X-3949-249-1	PANEL ASSY, FRONT (25:CP)		21	3-053-419-31	ESCUICHEON, CASSETTE (25:B)	
1	X-3949-250-1	PANEL ASSY, FRONT (20:EX,UX)		21	3-053-419-41	ESCUICHEON, CASSETTE(10:EE,EG,X10/30:EE)	
1	X-3949-251-1	PANEL ASSY, FRONT (20:VP1,VP2)		22	3-053-426-01	BUTTON (S), CENTER (EXCEPT 25:B10/30:E/40:B/45)	
1	X-3949-252-1	PANEL ASSY, FRONT (10:AE1,AE2)		22	3-053-426-11	BUTTON (S), CENTER (25:B/40:B)	
1	X-3949-253-1	PANEL ASSY, FRONT (40:EG)		22	3-053-231-01	BUTTON, CENTER (30:EE/45)	
1	X-3949-254-1	PANEL ASSY, FRONT (X40)		23	3-053-418-01	COVER (2P), JACK (30,45)	
1	X-3949-255-1	PANEL ASSY, FRONT (40:EE)		26	3-709-430-01	COVER, REMOTE CONTROL (30:UX,CP,VC1,VC2/45)	
1	X-3949-256-1	PANEL ASSY, FRONT (30:EE)		27	1-418-008-11	COMMANDER, STANDARD (RMT-V257) (20:VP1,VP2)	
1	X-3949-257-1	PANEL ASSY, FRONT (10:EE,EG)		27	1-418-008-21	COMMANDER, STANDARD (RMT-V257A) (25:B)	
1	X-3949-258-1	PANEL ASSY, FRONT (X10)		27	1-418-008-31	COMMANDER, STANDARD (RMT-V257B) (20:EX,UX/25:CP,VC,X25,40:CP,EG,VC1,VC2/X40)	
2	3-053-425-01	RING(S), BUTTON(EXCEPT 25:B/30:EE/40:B/45)		27	1-418-008-41	COMMANDER, STANDARD (RMT-V257C) (40:B)	
2	3-053-425-11	RING(S), BUTTON (25:B/40:B)		28	3-709-433-01	COVER, REMOTE CONTROL BATTERY (20/25/X25/40:B,CP,VC1,VC2,EG/X40)	
2	3-053-232-01	RING, JOG (30:EE/45)					
3	3-053-421-01	PLATE, JACK GROUND (30,45)					
4	3-053-417-01	PLATE, FROSTED (EXCEPT 40:B)					
4	3-053-417-11	PLATE, FROSTED (40:B)					
5	3-053-436-01	EMBLEM (NO.5), SONY					
* 6	A-6794-659-A	DS-83C BOARD, COMPLETE (45)					
* 6	A-6794-661-A	DS-83A BOARD, COMPLETE(EXCEPT 30:EE,45)					
* 6	A-6794-663-A	DS-83B BOARD, COMPLETE (30:EE)					
7	3-953-432-01	SPRING (GE), FL					
8	3-989-626-11	CUSHION (PS), RUBBER					
9	1-418-007-11	COMMANDER, STANDARD (RMT-V256) (10,X10,30:EE)					
9	1-418-007-21	COMMANDER, STANDARD(RMT-V256A)(40:EE)					
10	3-709-322-01	COVER, BATTERY (10,X10,30:EE,40:EE)					
* 11	A-6794-658-A	FI-15B BOARD, COMPLETE (30/45:EXCEPT EE)					

7-1-2. CHASSIS SECTION

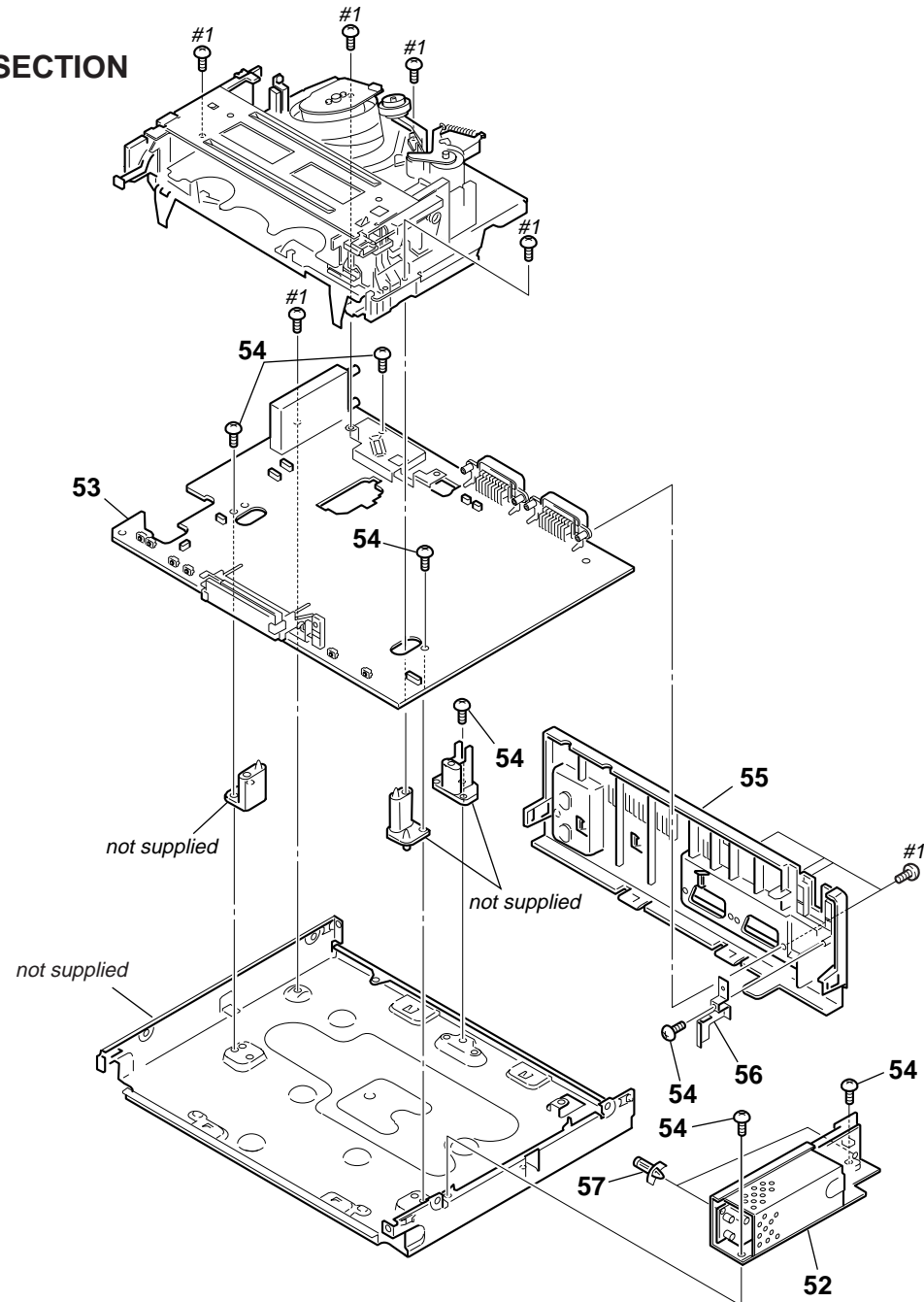

Ref. No.	Part No.	Description	Remarks	Ref. No.	Part No.	Description	Remarks
△ 52	1-468-271-31	POWER BLOCK (ETXNY165E1D)		* 53	A-6791-764-A	MA-338NN BOARD, COMPLETE (X25)	
* 53	A-6791-746-A	MA-338C BOARD, COMPLETE (45:VC)		* 53	A-6791-765-A	MA-338P BOARD, COMPLETE (10:AE1)	
* 53	A-6791-747-A	MA-338A BOARD, COMPLETE (45:UX)		* 53	A-6791-766-A	MA-338PN BOARD, COMPLETE (10:AE2)	
* 53	A-6791-748-A	MA-338B BOARD, COMPLETE (45:CP)		* 53	A-6791-767-A	MA-338Q BOARD, COMPLETE (40:EE)	
* 53	A-6791-749-A	MA-338D BOARD, COMPLETE (40:B)		* 53	A-6791-769-A	MA-338U BOARD, COMPLETE (10:EE)	
* 53	A-6791-750-A	MA-338F BOARD, COMPLETE (40:VC1)		* 53	A-6791-768-A	MA-338T BOARD, COMPLETE (30:EE)	
* 53	A-6791-751-A	MA-338FN BOARD, COMPLETE (40:VC2)		* 53	A-6791-770-A	MA-338V BOARD, COMPLETE (10:EG,X10)	
* 53	A-6791-752-A	MA-338E BOARD, COMPLETE (40:CP)		* 53	A-6791-771-A	MA-338S BOARD, COMPLETE (40:EG)	
* 53	A-6791-753-A	MA-338I BOARD, COMPLETE (30:VC1)		* 53	A-6791-772-A	MA-338R BOARD, COMPLETE (X40)	
* 53	A-6791-754-A	MA-338IN BOARD, COMPLETE (30:VC2)		54	3-970-608-21	SUMITITE (B3), +BV	
* 53	A-6791-755-A	MA-338G BOARD, COMPLETE (30:UX)		55	3-979-382-81	PANEL , REAR (E) (30:CP,VC1,VC2/45:CP,VC)	
* 53	A-6791-756-A	MA-338H BOARD, COMPLETE (30:CP)		55	3-979-382-91	PANEL , REAR (E) (30:EE)	
* 53	A-6791-757-A	MA-338O BOARD, COMPLETE (20:VP1)		55	3-053-409-01	PANEL (E), REAR (25/X25/40:B,CP,VC1,VC2)	
* 53	A-6791-758-A	MA-338ON BOARD, COMPLETE (20:VP2)		55	3-053-409-11	PANEL (E), REAR (30:UX/45:UX)	
* 53	A-6791-759-A	MA-338K BOARD, COMPLETE (20:UX)		55	3-053-409-21	PANEL (E), REAR (10:AE1,AE2)	
* 53	A-6791-760-A	MA-338J BOARD, COMPLETE (20:EX)		55	3-053-409-31	PANEL (E), REAR (10:EG/X10/20/40:EG/X40)	
* 53	A-6791-761-A	MA-338N BOARD, COMPLETE (25:VC)		55	3-053-409-41	PANEL (E), REAR (10:EE/40:EE)	
* 53	A-6791-762-A	MA-338L BOARD, COMPLETE (25:B)		56	3-053-431-01	BRACKET	
* 53	A-6791-763-A	MA-338M BOARD, COMPLETE (25:CP)		* 57	3-670-570-21	SPACER, SUPPORT	
* 53	A-6791-764-A	MA-338NN BOARD, COMPLETE (X25)					

Note :
The components identified by mark △ or dotted line with mark △ are critical for safety. Replace only with part number specified.

Note :
Les composants identifiés par une marque △ sont critiques pour la sécurité. Ne les remplacer que par une pièce portant le numéro spécifié.

7-1-3. MECHANISM DECK SECTION-1

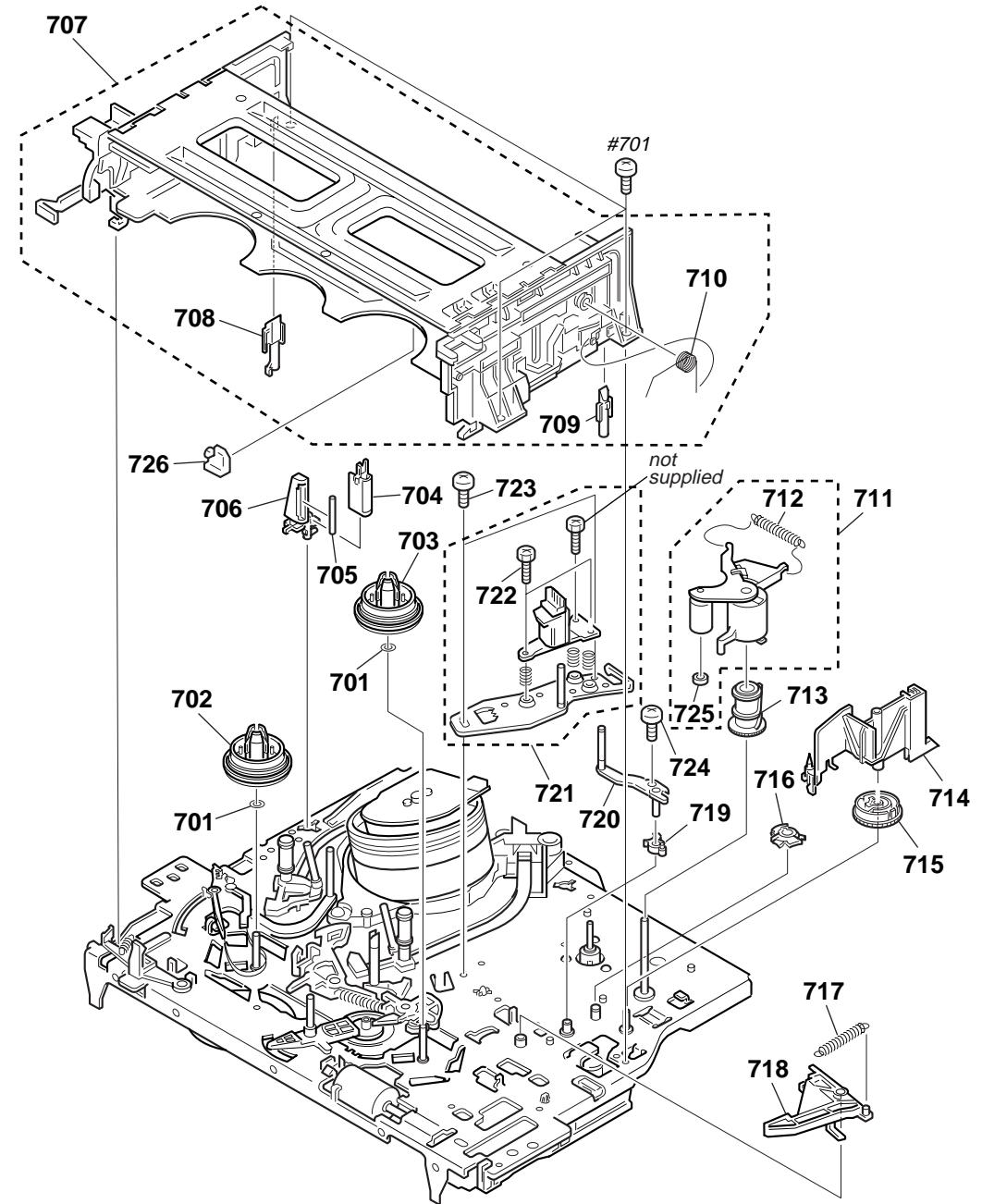

Ref. No.	Part No.	Description	Remarks	Ref. No.	Part No.	Description	Remarks
701	3-977-509-01	WASHER, THRUST		714	3-977-514-01	OPENER, LID	
702	3-977-507-01	TABLE, REEL (S)		715	3-977-441-01	GEAR, PINCH PRESSING	
703	3-977-508-01	TABLE, REEL (T)		716	3-977-445-01	GEAR, TG8 ARM DRIVING	
704	1-500-144-11	HEAD, FE		717	3-977-465-01	SPRING, EXTENSION (RVS BRAKE)	
705	3-977-495-01	SHAFT TG2		718	X-3947-582-1	ARM ASSY, RVS BRAKE	
706	3-977-494-01	HOLDER, FEH		719	3-977-446-01	GEAR, TG8 ARM	
707	A-6759-619-B	FL COMPLETE ASSY BOARD, COMPLETE		720	X-3947-590-1	TG8 ASSY	
708	3-977-535-01	PLATE, LUMINOUS (END SENSOR)		721	A-6775-052-A	ACEBLOCK ASSY (ALPS) (EURO 2)	
709	3-977-536-01	PLATE, LUMINOUS (TOP SENSOR)		722	3-974-556-11	+HEXA TT 2.6 × 9 (TAPER)	
710	3-970-471-01	SPRING (DECK OPEN), TORSION		723	3-979-508-01	SCREW +HEXA TP SW 3 × 8	
711	A-6759-615-A	PRESS BLOCK ASSY, PINCH		724	3-719-381-01	SCREW (M2 × 4)	
712	3-958-455-01	SPRING (PINCH), TENSION		725	3-736-045-01	BEARING (NO FLANG), BALL	
713	3-977-447-01	GEAR, ELEVATOR		726	3-055-098-01	GUIDE, TAPE	

7-1-4. MECHANISM DECK SECTION-2

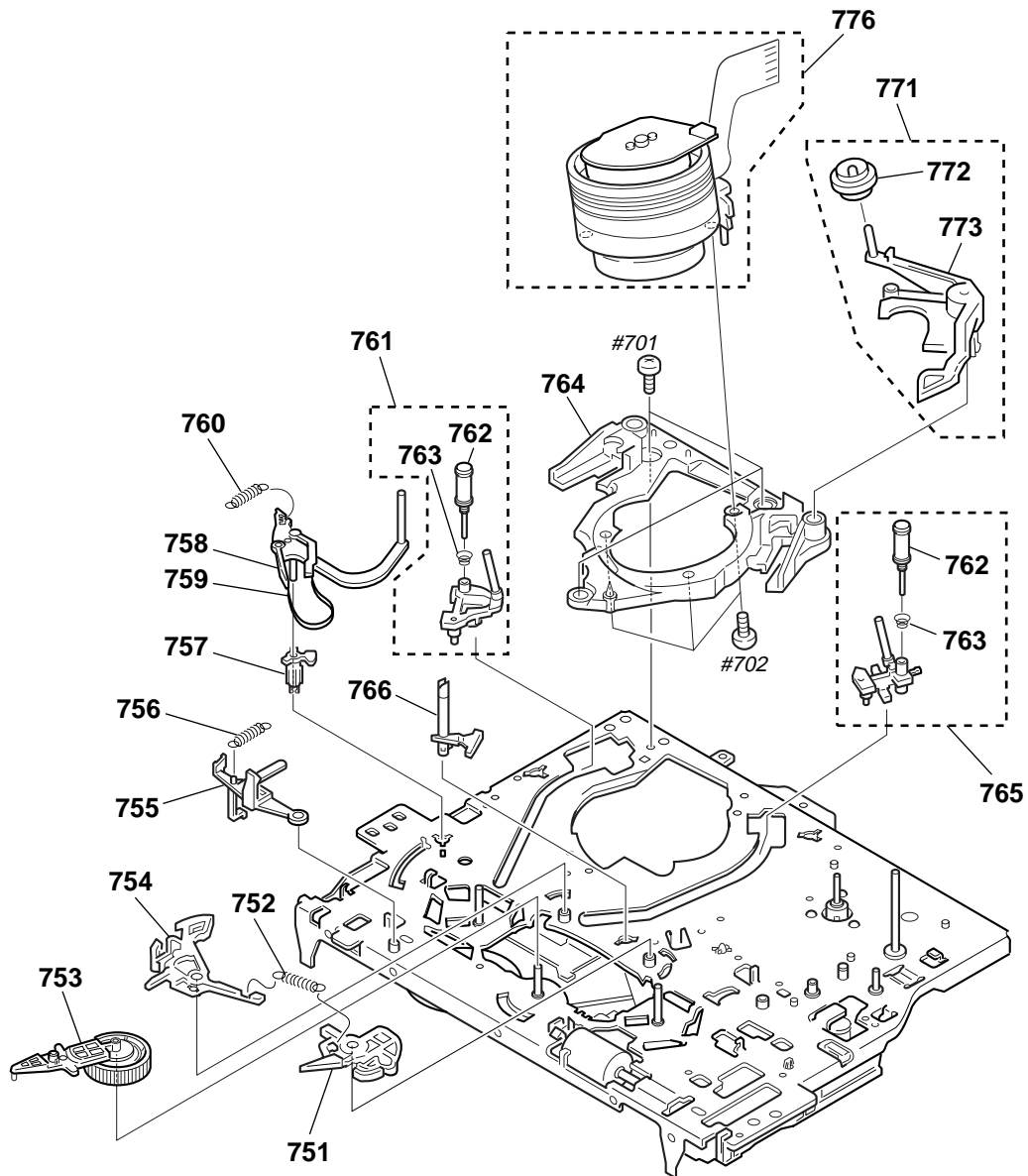

Ref. No.	Part No.	Description	Remarks	Ref. No.	Part No.	Description	Remarks
751	X-3947-581-4	BRAKE ASSY, MAIN(T)		763	3-965-178-01	SPRING	
752	3-977-462-01	SPRING,EXTENTION. (MAIN BRAKE)		764	3-969-632-04	BASE, DRUM	
753	X-3947-573-1	ARM ASSY, PENDULUM		765	A-6750-328-E	SHUTTLE (T) BLOCK ASSY	
754	X-3947-580-5	BRAKE ASSY, MAIN(S)		766	3-977-501-01	PLATE, LUMINOUS	
755	3-977-513-02	LEVER, REC. PROOF		771	A-6746-074-G	ROLLER BLOCK ASSY, HC	
756	3-976-767-01	SPRING, TENS. (REC. PROOF)		772	X-3947-255-1	ROLLER ASSY, HC	
757	3-977-487-01	BOSS, TG1 FULCRUM		773	3-975-724-07	ARM, HC	
758	X-3947-587-1	TG1 ASSY		776	1-759-791-11	DRUM ASSY, DZH-78D-R	(10/X10/20:VP1,VP2/25:B/30:EE)
759	X-3947-589-1	BAND ASSY, TG1		776	1-759-793-11	DRUM ASSY, DZH-92B-R	(20:EX,UX/25:CP,VC/X25/30:CP,UX,VC1,VC2,X25)
760	3-977-488-01	SPRING (POWER TENSION)		776	1-759-795-11	DRUM ASSY, DZH-93B-R	(40/X40/45)
761	A-6750-324-A	SHUTTLE (S) BLOCK ASSY					
762	X-3944-378-1	ROLLER ASSY, GUIDE					

7-1-5. MECHANISM DECK SECTION-3

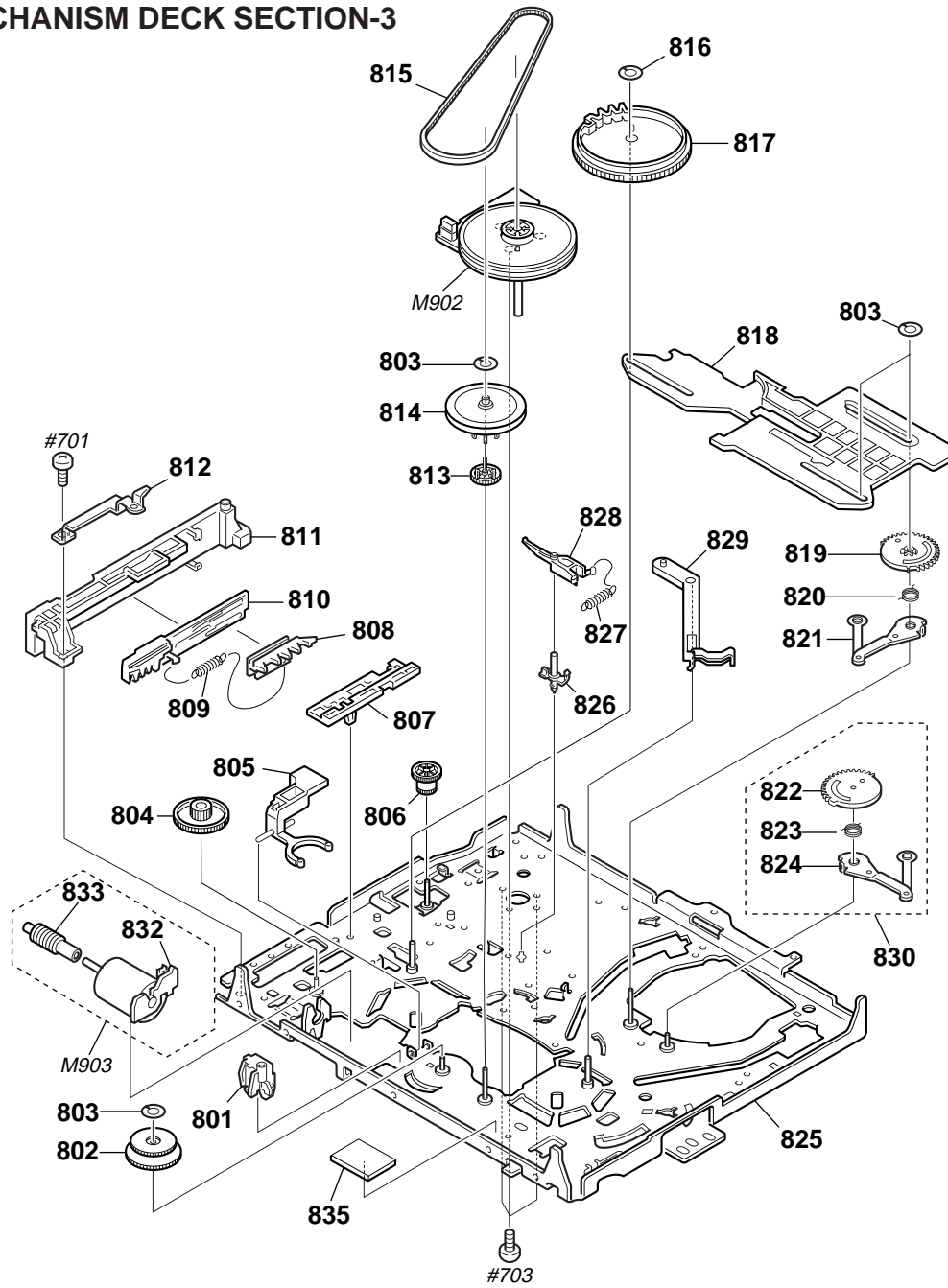

Ref. No.	Part No.	Description	Remarks	Ref. No.	Part No.	Description	Remarks
801	3-977-437-01	RETAINER,CAM MOTOR		819	3-977-455-01	GEAR, LOADING(T)	
802	X-3947-584-1	ASSY, REEL DIRECT		820	3-977-456-03	SPRING, TORSION (LOAD T)	
803	3-977-443-01	WASHER, STOPPER		821	X-3947-579-1	LEVER ASSY, LOADING(T)	
804	3-977-438-01	WORM - WHEEL		822	3-977-451-01	GEAR, LOADING(S)	
805	3-977-506-01	ARM, LIMITTER SELECTION		823	3-977-452-01	SPRING, TORSION (LOAD S)	
806	3-977-444-01	GEAR, PINCH TRANSMISSION		824	X-3947-578-1	LEVER ASSY, LOADING(S)	
807	3-977-515-01	GUIDE, FL SLIDER		825	X-3947-576-2	CHASSIS ASSY, MECHANICAL	
808	3-977-517-01	PLATE, SLIDE, FL		826	3-977-468-01	SHAFT, CAPSTAN BRAKE	
809	3-977-519-01	SPRING, TENS. (LIMIT, FL)		827	3-977-467-02	SPRING, CAP BRAKE	
810	3-977-518-02	PLATE, LIMITTER, FL		828	X-3947-583-1	BRAKE ASSY, CAPSTAN	
811	3-977-516-01	HOLDER, FL SLIDER		829	3-977-489-01	ARM, TG1 DRIVING	
812	3-977-877-01	PLATE, RETAINER		830	A-6759-616-A	GEAR BLOCK ASSY, LOADING(S)	
813	3-977-504-01	GEAR, CLUTCH		832	1-766-723-21	CONNECTOR, BOARD TO BOAR 3P	
814	X-3947-585-1	GEAR ASSY, PULLEY		833	3-977-436-01	WORM	
815	3-977-510-01	BELT, RUBBER		835	3-989-917-01	SPACER (REC PROOF)	
816	3-977-440-01	WASHER, STOPPER		M902	1-698-971-11	MOTOR, DC	
817	3-977-439-01	GEAR, CAM		M903	X-3947-577-1	MOTOR ASSY, CAM	
818	3-977-442-01	SLIDER					

7-2. ELECTRICAL PARTS LIST

NOTE:

- Due to standardization, replacements in the parts list may be different from the parts specified in the diagrams or the components used on the set.
- -XX, -X mean standardized parts, so they may have some difference from the original one.
- Items marked "*" are not stocked since they are seldom required for routine service. Some delay should be anticipated when ordering these items.
- CAPACITORS:
uF: μ F

- RESISTORS
All resistors are in ohms.
METAL: metal-film resistor
METAL OXIDE: Metal Oxide-film resistor
F: nonflammable
- COILS
uH: μ H
- Abbreviation
X10 : SX10
X25 : SX25
X40 : SX40

When indicating parts by reference number, please include the board name.

- SEMICONDUCTORS
In each case, u: μ , for example:
uA...: μ A... , uPA... , μ PA... ,
uPB... , μ PB... , uPC... , μ PC... ,
uPD... , μ PD...

The components identified by mark Δ or dotted line with mark Δ are critical for safety. Replace only with part number specified.

Les composants identifiés par une marque Δ sont critiques pour la sécurité. Ne les remplacer que par une pièce portant le numéro spécifié.

Ref. No.	Part No.	Description	Remarks	Ref. No.	Part No.	Description	Remarks
*	A-6794-659-A	DS-83C BOARD, COMPLETE (45) *****				< DIODE >	
*	A-6794-661-A	DS-83A BOARD, COMPLETE ***** (EXCEPT 30,45:EE)		D481	8-719-067-40	DIODE STZ6.8N-T146 (30,45)	
				D485	8-719-045-63	DIODE SLR342YC-A-47(30:EE)	
				D491	8-719-067-40	DIODE STZ6.8N-T146(30,45)	
				D493	8-719-070-59	DIODE PDZ6.8B-115(30,45)	
*	A-6794-663-A	DS-83B BOARD, COMPLETE (30: EE) ***** (Ref. NO:1,000 series)				< JACK >	
		< CONNECTOR >		J481	1-774-510-11	JACK, PIN 2P (LINE-2 IN) (30,45)	
*	CN450	1-750-737-11 CONNECTOR, FFC/FPC 5P (30,45:EE)				< TRANSISTOR >	
		< DIODE >		Q485	8-729-043-29	TRANSISTOR PDTC144EK-115 (30:EE)	
D450	8-719-056-06	DIODE SLR-342DC3F (JOG) (45)				< RESISTOR >	
D451	8-719-988-61	DIODE 1SS355TE-17 (45)		R480	1-216-022-00	METAL CHIP 75 5% 1/10W (30, 45)	
		< RESISTOR >		R485	1-216-041-00	METAL CHIP 470 5% 1/10W (30: EE)	
R450	1-216-053-00	METAL CHIP 1.5K 5% 1/10W		R491	1-216-041-00	METAL CHIP 470 5% 1/10W (30, 45)	
R451	1-216-049-91	RES,CHIP 1K 5% 1/10W				< SWITCH >	
		< SWITCH >		S485	1-762-196-21	SWITCH, TACT(SURROUND)(30:EE)	
S450	1-762-196-21	SWITCH, TACT(FF) (30,45:EE)					
S451	1-762-196-21	SWITCH, TACT(FF) (EXCEPT 30,45: EE)		*	A-6791-746-A	MA-338C BOARD, COMPLETE (45: VC) *****	
S452	1-762-196-21	SWITCH, TACT(PLAY) (EXCEPT 30,45: EE)		*	A-6791-747-A	MA-338A BOARD, COMPLETE (45: UX) *****	
S453	1-762-196-21	SWITCH, TACT(STOP) (EXCEPT 30,45: EE)		*	A-6791-748-A	MA-338B BOARD, COMPLETE (45: CP) *****	
S454	1-762-196-21	SWITCH, TACT(REW) (EXCEPT 30,45: EE)		*	A-6791-749-A	MA-338D BOARD, COMPLETE (40: B) *****	
S455	1-762-196-21	SWITCH, TACT (REW) (30,45:EE)		*	A-6791-750-A	MA-338F BOARD, COMPLETE (40: VC1) *****	
S456	1-762-196-21	SWITCH, TACT (JOG) (45)		*	A-6791-751-A	MA-338FN BOARD, COMPLETE (40: VC2) *****	
*	A-6794-658-A	FI-15B BOARD, COMPLETE(30: EXCEPT EE/45) *****		*	A-6791-752-A	MA-338E BOARD, COMPLETE(40: CP) *****	
*	A-6794-662-A	FI-15A BOARD, COMPLETE (30: EE) ***** (Ref. NO:1,000 series)		*	A-6791-753-A	MA-338I BOARD, COMPLETE(30: VC1) *****	
		< CAPACITOR >		*	A-6791-754-A	MA-338IN BOARD, COMPLETE (30: VC2) *****	
C481	1-163-009-11	CERAMIC CHIP 0.001uF 10% 50V (30,45)					
C493	1-163-009-11	CERAMIC CHIP 0.001uF 10% 50V (30,45)					
		< CONNECTOR >					
CN480	1-573-130-21	PIN, CONNECTOR 7P (30: EE)					
CN480	1-506-469-11	PIN, CONNECTOR 4P (30: EXCEPT EE/45)					

MA-338

Ref. No.	Part No.	Description	Remarks	Ref. No.	Part No.	Description	Remarks
*	A-6791-755-A	MA-338G BOARD, COMPLETE (30: UX) *****		C107	1-124-589-11	ELECT 47uF 20%	16V
*	A-6791-756-A	MA-338H BOARD, COMPLETE (30: CP) *****		C113	1-163-021-91	CERAMIC CHIP 0.01uF 10%	50V
*	A-6791-757-A	MA-338O BOARD, COMPLETE (20: VP1) *****		C114	1-163-021-91	CERAMIC CHIP 0.01uF 10%	50V
*	A-6791-758-A	MA-338ON BOARD, COMPLETE (20: VP2) *****		C115	1-163-038-91	CERAMIC CHIP 0.1uF 25V	
*	A-6791-759-A	MA-338K BOARD, COMPLETE (20: UX) *****		C120	1-163-021-91	CERAMIC CHIP 0.01uF 10%	50V
*	A-6791-760-A	MA-338J BOARD, COMPLETE (20: EX) *****		C121	1-163-021-91	CERAMIC CHIP 0.01uF 10%	50V
*	A-6791-761-A	MA-338N BOARD, COMPLETE (25: VC) *****		C122	1-124-589-11	ELECT 47uF 20%	16V
*	A-6791-762-A	MA-338L BOARD, COMPLETE (25: B) *****		C123	1-163-021-91	CERAMIC CHIP 0.01uF 10%	50V
*	A-6791-763-A	MA-338M BOARD, COMPLETE (25: CP) *****		C131	1-124-589-11	ELECT 47uF 20%	16V
*	A-6791-764-A	MA-338NN BOARD, COMPLETE (X25) *****		C133	1-163-021-91	CERAMIC CHIP 0.01uF 10%	50V
*	A-6791-765-A	MA-338P BOARD, COMPLETE (10: AE1) *****		C134	1-163-021-91	CERAMIC CHIP 0.01uF 10%	50V
*	A-6791-766-A	MA-338PN BOARD, COMPLETE (10: AE2) *****		C140	1-124-584-00	ELECT 100uF 20%	10V
*	A-6791-767-A	MA-338Q BOARD, COMPLETE (40: EE) *****		C141	1-164-004-11	CERAMIC CHIP 0.1uF 10%	25V
*	A-6791-769-A	MA-338U BOARD, COMPLETE (10: EE) *****		C142	1-163-037-11	CERAMIC CHIP 0.022uF 10%	25V
*	A-6791-768-A	MA-338T BOARD, COMPLETE (30: EE) *****		C143	1-128-131-11	ELECT 22uF 20%	50V
*	A-6791-770-A	MA-338V BOARD, COMPLETE (10: EG, X10) *****		C144	1-128-131-11	ELECT 22uF 20%	50V
*	A-6791-771-A	MA-338S BOARD, COMPLETE (40: EG) *****		C145	1-124-584-00	ELECT 100uF 20%	10V
*	A-6791-772-A	MA-338R BOARD, COMPLETE (X40) *****		C146	1-164-161-11	CERAMIC CHIP 0.0022uF 10%	100V
		(Ref. NO:1,000 series)		C160	1-163-021-91	CERAMIC CHIP 0.01uF 10%	50V
	3-053-427-01	HOLDER, INDICATION TUBE		C161	1-163-021-91	CERAMIC CHIP 0.01uF 10%	50V
	3-053-428-01	BASE, INDICATION TUBE		C162	1-104-905-11	CAPACITOR 0.22F 5.5V	
*	3-960-273-01	SPACER, TOP END		C163	1-163-038-91	CERAMIC CHIP 0.1uF 25V	
*	3-960-274-01	SPACER, LED		C164	1-124-584-00	ELECT 100uF 20%	10V
		< CAPACITOR >		C165	1-163-038-91	CERAMIC CHIP 0.1uF 25V	
C100	1-163-009-11	CERAMIC CHIP 0.001uF 10%	50V	C166	1-163-021-91	CERAMIC CHIP 0.01uF 10%	50V
C101	1-163-009-11	CERAMIC CHIP 0.001uF 10%	50V	C167	1-163-809-11	CERAMIC CHIP 0.047uF 10%	25V
C102	1-163-009-11	CERAMIC CHIP 0.001uF 10%	50V	C168	1-163-237-11	CERAMIC CHIP 27PF 5%	50V
C103	1-128-057-11	ELECT 330uF 20%	6.3V	C169	1-163-234-11	CERAMIC CHIP 20PF 5%	50V
C105	1-163-009-11	CERAMIC CHIP 0.001uF 10%	50V	C170	1-164-004-11	CERAMIC CHIP 0.1uF 10%	25V
				C171	1-163-233-11	CERAMIC CHIP 18PF 5%	50V
				C172	1-163-233-11	CERAMIC CHIP 18PF 5%	50V
				C173	1-163-007-11	CERAMIC CHIP 680PF 10%	50V
				C200	1-163-021-91	CERAMIC CHIP 0.01uF 10%	50V
				C201	1-109-982-11	CERAMIC CHIP 1uF 10%	10V
				C202	1-163-021-91	CERAMIC CHIP 0.01uF 10%	50V
				C203	1-163-809-11	CERAMIC CHIP 0.047uF 10%	25V
				C204	1-163-021-91	CERAMIC CHIP 0.01uF 10%	50V
				C205	1-163-239-11	CERAMIC CHIP 33PF 5%	50V
				C206	1-163-809-11	CERAMIC CHIP 0.047uF 10%	25V
				C207	1-163-237-11	CERAMIC CHIP 27PF 5%	50V
				C208	1-109-982-11	CERAMIC CHIP 1uF 10%	10V
				C209	1-163-257-11	CERAMIC CHIP 180PF 5%	50V
				C210	1-163-235-11	CERAMIC CHIP 22PF 5%	50V
				C211	1-109-982-11	CERAMIC CHIP 1uF 10%	10V
				C212	1-163-809-11	CERAMIC CHIP 0.047uF 10%	25V
				C213	1-109-982-11	CERAMIC CHIP 1uF 10%	10V
				C214	1-164-004-11	CERAMIC CHIP 0.1uF 10%	25V
				C215	1-163-021-91	CERAMIC CHIP 0.01uF 10%	50V
				C216	1-163-037-11	CERAMIC CHIP 0.022uF 10%	25V
				C217	1-163-021-91	CERAMIC CHIP 0.01uF 10%	50V
				C218	1-163-021-91	CERAMIC CHIP 0.01uF 10%	50V
				C219	1-163-038-91	CERAMIC CHIP 0.1uF 25V	
				C220	1-124-589-11	ELECT 47uF 20%	16V
				C221	1-164-004-11	CERAMIC CHIP 0.1uF 10%	25V
						(10/20:VP1,VP2/25:B/30:EE/40/45/X10/X40)	
				C221	1-109-982-11	CERAMIC CHIP 1uF 10%	10V
						(20:EX,UX/25:CP,VC/30:EXCEPT EE/X25)	

Ref. No.	Part No.	Description	Remarks	Ref. No.	Part No.	Description	Remarks
C222	1-109-982-11	CERAMIC CHIP	1uF 10% 10V	C309	1-137-370-11	FILM	0.01uF 5% 50V
C223	1-163-038-91	CERAMIC CHIP	0.1uF 25V	C310	1-126-163-11	ELECT	4.7uF 20% 50V
C224	1-163-021-91	CERAMIC CHIP	0.01uF 10% 50V	C312	1-126-966-11	ELECT	33uF 20% 16V
C225	1-124-589-11	ELECT	47uF 20% 16V	C313	1-109-982-11	CERAMIC CHIP	1uF 10% 10V
C226	1-163-038-91	CERAMIC CHIP	0.1uF 25V	C314	1-126-157-11	ELECT	10uF 20% 16V
C227	1-124-589-11	ELECT	47uF 20% 16V	C315	1-109-982-11	CERAMIC CHIP	1uF 10% 10V
C228	1-163-131-00	CERAMIC CHIP	390PF 5% 50V	C316	1-126-163-11	ELECT	4.7uF 20% 50V
C229	1-164-004-11	CERAMIC CHIP	0.1uF 10% 25V	C317	1-163-011-11	CERAMIC CHIP	0.0015uF 10% 50V
C230	1-163-038-91	CERAMIC CHIP	0.1uF 25V	C318	1-126-160-11	ELECT	1uF 20% 50V
C231	1-109-982-11	CERAMIC CHIP	1uF 10% 10V	C319	1-109-982-11	CERAMIC CHIP	1uF 10% 10V (30,45)
C232	1-109-982-11	CERAMIC CHIP	1uF 10% 10V	C320	1-163-038-91	CERAMIC CHIP	0.1uF 25V
C233	1-164-004-11	CERAMIC CHIP	0.1uF 10% 25V	C321	1-124-589-11	ELECT	47uF 20% 16V
C234	1-163-038-91	CERAMIC CHIP	0.1uF 25V	C322	1-109-982-11	CERAMIC CHIP	1uF 10% 10V
C235	1-109-982-11	CERAMIC CHIP	1uF 10% 10V	C323	1-137-397-11	FILM	0.047uF 5% 100V
C236	1-163-243-11	CERAMIC CHIP	47PF 5% 50V (10,30,40: EXCEPT EE)	C324	1-163-038-91	CERAMIC CHIP	0.1uF 25V
C237	1-164-004-11	CERAMIC CHIP	0.1uF 10% 25V	C325	1-124-589-11	ELECT	47uF 20% 16V
C238	1-126-157-11	ELECT	10uF 20% 16V	C326	1-163-021-91	CERAMIC CHIP	0.01uF 10% 50V
C239	1-163-243-11	CERAMIC CHIP	47PF 5% 50V (30:EXCEPT EE/45)	C327	1-163-021-91	CERAMIC CHIP	0.01uF 10% 50V
C240	1-163-243-11	CERAMIC CHIP	47PF 5% 50V (10/20/30:EE/EXCEPT 40:EE,EG/X40)	C420	1-124-589-11	ELECT	47uF 20% 16V
C241	1-164-004-11	CERAMIC CHIP	0.1uF 10% 25V (30,45)	C421	1-163-235-11	CERAMIC CHIP	22PF 5% 50V
C242	1-164-004-11	CERAMIC CHIP	0.1uF 10% 25V (10/20/30:EE/EXCEPT 40:EE,EG/X40)	C422	1-163-038-91	CERAMIC CHIP	0.1uF 25V
C243	1-163-809-11	CERAMIC CHIP	0.047uF 10% 25V	C423	1-164-004-11	CERAMIC CHIP	0.1uF 10% 25V
C244	1-163-021-91	CERAMIC CHIP	0.01uF 10% 50V	C424	1-126-157-11	ELECT	10uF 20% 16V
C245	1-163-038-91	CERAMIC CHIP	0.1uF 25V	C460	1-163-021-91	CERAMIC CHIP	0.01uF 10% 50V
C246	1-163-038-91	CERAMIC CHIP	0.1uF 25V	C500	1-163-017-00	CERAMIC CHIP	0.0047uF 5% 50V
C247	1-163-021-91	CERAMIC CHIP	0.01uF 10% 50V	C510	1-163-021-91	CERAMIC CHIP	0.01uF 10% 50V
C248	1-124-589-11	ELECT	47uF 20% 16V	C511	1-124-589-11	ELECT	47uF 20% 16V
C249	1-126-157-11	ELECT	10uF 20% 16V	C512	1-124-589-11	ELECT	47uF 20% 16V
C250	1-124-589-11	ELECT	47uF 20% 16V	C513	1-126-935-11	ELECT	470uF 20% 6.3V
C251	1-126-153-11	ELECT	22uF 20% 6.3V	C571	1-163-017-00	CERAMIC CHIP	0.0047uF 5% 50V (10/20/30:EE/EXCEPT 40:EE,EG/X40)
C252	1-164-489-11	CERAMIC CHIP	0.22uF 10% 16V	C572	1-164-004-11	CERAMIC CHIP	0.1uF 10% 25V (10/20/30:EE/EXCEPT 40:EE,EG/X40)
C253	1-163-139-00	CERAMIC CHIP	820PF 5% 50V (40:B)	C580	1-126-964-11	ELECT	10uF 20% 50V (10/20/30:EE/EXCEPT 40:EE,EG/X40)
C253	1-163-137-00	CERAMIC CHIP	680PF 5% 50V (25:B)	C581	1-126-964-11	ELECT	10uF 20% 50V (10/20/30:EE/EXCEPT 40:EE,EG/X40)
C255	1-163-031-11	CERAMIC CHIP	0.01uF 50V	C582	1-124-261-00	ELECT	10uF 20% 50V (10/20/30:EE/EXCEPT 40:EE,EG/X40)
C271	1-163-021-91	CERAMIC CHIP	0.01uF 10% 50V (40,45,X40)	C583	1-126-964-11	ELECT	10uF 20% 50V (10/20/30:EE/EXCEPT 40:EE,EG/X40)
C272	1-164-004-11	CERAMIC CHIP	0.1uF 10% 25V (40,45,X40)	C584	1-164-004-11	CERAMIC CHIP	0.1uF 10% 25V (10/20/30:EE/EXCEPT 40:EE,EG/X40)
C275	1-163-021-91	CERAMIC CHIP	0.01uF 10% 50V	C585	1-126-964-11	ELECT	10uF 20% 50V (25/45/40:B,CP,VC1,VC2/30/X25)
C276	1-164-004-11	CERAMIC CHIP	0.1uF 10% 25V	C586	1-126-964-11	ELECT	10uF 20% 50V (10/20/30:EE/EXCEPT 40:EE,EG/X40)
C278	1-163-037-11	CERAMIC CHIP	0.022uF 10% 25V	C587	1-126-964-11	ELECT	10uF 20% 50V (B,CP,VC,VC1,VC2)
C279	1-164-004-11	CERAMIC CHIP	0.1uF 10% 25V	C588	1-126-964-11	ELECT	10uF 20% 50V (25/30/40:B,CP,VC1,VC2/45/X25)
C280	1-124-584-00	ELECT	100uF 20% 10V	C600	1-128-131-11	ELECT	22uF 20% 50V
C281	1-163-021-91	CERAMIC CHIP	0.01uF 10% 50V	C601	1-163-021-91	CERAMIC CHIP	0.01uF 10% 50V
C282	1-163-021-91	CERAMIC CHIP	0.01uF 10% 50V	C603	1-128-131-11	ELECT	22uF 20% 50V
C283	1-163-021-91	CERAMIC CHIP	0.01uF 10% 50V	C604	1-124-589-11	ELECT	47uF 20% 16V
C284	1-164-489-11	CERAMIC CHIP	0.22uF 10% 16V	C605	1-128-131-11	ELECT	22uF 20% 50V
C285	1-163-021-91	CERAMIC CHIP	0.01uF 10% 50V	C607	1-164-004-11	CERAMIC CHIP	0.1uF 10% 25V
C288	1-163-251-11	CERAMIC CHIP	100PF 5% 50V	C608	1-128-131-11	ELECT	22uF 20% 50V
C306	1-163-021-91	CERAMIC CHIP	0.01uF 10% 50V	C609	1-124-589-11	ELECT	47uF 20% 16V
C307	1-126-157-11	ELECT	10uF 20% 16V	C610	1-128-131-11	ELECT	22uF 20% 50V
C308	1-163-011-11	CERAMIC CHIP	0.0015uF 10% 50V				

MA-338

Ref. No.	Part No.	Description	Remarks			Ref. No.	Part No.	Description	Remarks		
C611	1-128-131-11	ELECT	22uF	20%	50V (B,CP,VC,VC1,VC2)	C970	1-163-259-91	CERAMIC CHIP	220PF	5%	50V (25:B/40:B)
C612	1-164-004-11	CERAMIC CHIP	0.1uF	10%	25V (B,CP,VC,VC1,VC2)	C971	1-124-257-00	ELECT	2.2uF	20%	50V (25:B/40:B)
C613	1-124-589-11	ELECT	47uF	20%	16V (B,CP,VC,VC1,VC2)	C972	1-163-017-00	CERAMIC CHIP	0.0047uF	5%	50V (25:B/40:B)
C615	1-164-004-11	CERAMIC CHIP	0.1uF	10%	25V	C973	1-163-021-91	CERAMIC CHIP	0.01uF	10%	50V (25:B/40:B)
C660	1-163-234-11	CERAMIC CHIP	20PF	5%	50V	C974	1-109-982-11	CERAMIC CHIP	1uF	10%	10V (25:B/40:B)
C661	1-163-235-11	CERAMIC CHIP	22PF	5%	50V	C975	1-163-037-11	CERAMIC CHIP	0.022uF	10%	25V (25:B/40:B)
C662	1-163-017-00	CERAMIC CHIP	0.0047uF	5%	50V	C976	1-163-259-91	CERAMIC CHIP	220PF	5%	50V (25:B/40:B)
C663	1-163-021-91	CERAMIC CHIP	0.01uF	10%	50V	C977	1-163-021-91	CERAMIC CHIP	0.01uF	10%	50V (25:B/40:B)
C664	1-163-038-91	CERAMIC CHIP	0.1uF		25V	C978	1-163-017-00	CERAMIC CHIP	0.0047uF	5%	50V (25:B/40:B)
C665	1-163-245-11	CERAMIC CHIP	56PF	5%	50V (B,EE,EG)	C979	1-163-121-00	CERAMIC CHIP	150PF	5%	50V (25:B/40:B)
C666	1-163-135-00	CERAMIC CHIP	560PF	5%	50V	C980	1-164-004-11	CERAMIC CHIP	0.1uF	10%	25V (25:B/40:B)
C667	1-164-004-11	CERAMIC CHIP	0.1uF	10%	25V	C981	1-163-021-91	CERAMIC CHIP	0.01uF	10%	50V (25:B/40:B)
C668	1-124-584-00	ELECT	100uF	20%	10V	C982	1-163-007-11	CERAMIC CHIP	680PF	10%	50V (25:B/40:B)
C669	1-163-016-00	CERAMIC CHIP	0.0039uF	10%	50V	C983	1-163-009-11	CERAMIC CHIP	0.001uF	10%	50V (25:B/40:B)
C670	1-109-982-11	CERAMIC CHIP	1uF	10%	10V	C984	1-163-021-91	CERAMIC CHIP	0.01uF	10%	50V (25:B/40:B)
C671	1-163-235-11	CERAMIC CHIP	22PF	5%	50V	C985	1-163-251-11	CERAMIC CHIP	100PF	5%	50V (25:B/40:B)
C672	1-163-038-91	CERAMIC CHIP	0.1uF		25V	C986	1-126-964-11	ELECT	10uF	20%	50V (25:B/40:B)
C701	1-124-261-00	ELECT	10uF	20%	50V	C987	1-107-823-11	CERAMIC CHIP	0.47uF	10%	16V (25:B/40:B)
C704	1-126-964-11	ELECT	10uF	20%	50V	C988	1-163-251-11	CERAMIC CHIP	100PF	5%	50V (25:B/40:B)
C705	1-163-809-11	CERAMIC CHIP	0.047uF	10%	25V	C991	1-164-004-11	CERAMIC CHIP	0.1uF	10%	25V (25:B/40:B)
C708	1-104-664-11	ELECT	47uF	20%	16V	C992	1-163-021-91	CERAMIC CHIP	0.01uF	10%	50V (25:B/40:B)
C709	1-163-021-91	CERAMIC CHIP	0.01uF	10%	50V	C993	1-163-021-91	CERAMIC CHIP	0.01uF	10%	50V (25:B/40:B)
C710	1-128-131-11	ELECT	22uF	20%	50V (10:EE,EG/30:EE/EXCEPT 40:EE,EG)	C994	1-163-021-91	CERAMIC CHIP	0.01uF	10%	50V (25:B/40:B)
C750	1-126-933-11	ELECT	100uF	20%	16V (10:EE/30:EE/40:EE)	C995	1-126-157-11	ELECT	10uF	20%	16V (25:B/40:B)
C751	1-163-021-91	CERAMIC CHIP	0.01uF	10%	50V (10:EE/30:EE/40:EE)	C996	1-163-227-11	CERAMIC CHIP	10PF	0.5PF	50V (25:B/40:B)
C752	1-126-933-11	ELECT	100uF	20%	16V	< CONNECTOR >					
C753	1-164-004-11	CERAMIC CHIP	0.1uF	10%	25V	* CN101	1-573-128-11	PIN, CONNECTOR	5P		
C754	1-126-935-11	ELECT	470uF	20%	6.3V	CN102	1-779-723-11	CONNECTOR, BOARD TO BOARD	9P		
C801	1-163-021-91	CERAMIC CHIP	0.01uF	10%	50V (10/30:EE/EXCEPT 40:EE/X10/X40)	* CN104	1-766-716-11	CONNECTOR, BOARD TO BOARD	3P		
C850	1-163-038-91	CERAMIC CHIP	0.1uF		25V (EXCEPT CP,EE,10,X10,X40)	CN140	1-506-468-11	PIN, CONNECTOR	3P		
C851	1-124-261-00	ELECT	10uF	20%	50V (EXCEPT CP,EE,10,X10,X40)	CN160	1-506-473-11	PIN, CONNECTOR	8P (30,45:EE)		
C852	1-164-161-11	CERAMIC CHIP	0.0022uF	10%	100V (EXCEPT CP,EE,10,X10,X40)	CN160	1-506-469-11	PIN, CONNECTOR	4P (EXCEPT 30:EE,45)		
C853	1-163-989-11	CERAMIC CHIP	0.033uF	10%	25V (EXCEPT CP,EE,10,X10,X40)	CN161	1-506-469-11	PIN, CONNECTOR	4P		
C855	1-164-489-11	CERAMIC CHIP	0.22uF	10%	16V (EXCEPT CP,EE,10,X10,X40)	CN260	1-785-550-11	CONNECTOR, FFC/FPC	8P		
C856	1-163-038-91	CERAMIC CHIP	0.1uF		25V (EXCEPT CP,EE,10,X10,X40)	* CN262	1-560-893-00	PIN, CONNECTOR	5P		
C870	1-124-589-11	ELECT	47uF	20%	16V (30:EE)	CN300	1-506-468-11	PIN, CONNECTOR	3P		
C871	1-124-261-00	ELECT	10uF	20%	50V (30:EE)						
C872	1-124-261-00	ELECT	10uF	20%	50V (30:EE)						
C873	1-163-017-00	CERAMIC CHIP	0.0047uF	5%	50V (30:EE)						
C874	1-163-017-00	CERAMIC CHIP	0.0047uF	5%	50V (30:EE)						

Ref. No.	Part No.	Description	Remarks	Ref. No.	Part No.	Description	Remarks
CN301	1-506-469-11	PIN, CONNECTOR 4P				< TERMINAL >	
* CN500	1-695-935-11	CONNECTOR (SQUARE TYPE) 21P (10,30,40:EXCEPT EE)		ET600	1-537-770-21	TERMINAL BOARD, GROUND	
CN501	1-506-469-11	PIN, CONNECTOR 4P (30:EXCEPT EE/45)				< FILTER >	
CN501	1-573-130-21	PIN, CONNECTOR 7P (30:EE)					
* CN570	1-695-935-11	CONNECTOR (SQUARE TYPE) 21P (10/20/30:EE/EXCEPT 40:EE,EG/X40)		FL500	1-236-163-11	ENCAPSULATED COMPONENT	
				FL501	1-236-163-11	ENCAPSULATED COMPONENT (30:EE)	
CN600	1-569-667-11	CONNECTOR, BOARD TO BOARD 8P		FL502	1-236-163-11	ENCAPSULATED COMPONENT	
		< JACK >		FL570	1-236-163-11	ENCAPSULATED COMPONENT (10/20/30:EE/EXCEPT 40:EE,EG/X40)	
CNJ500	1-779-010-11	JACK, PIN 4P (LINE-1(TV)) (10:EE/40:EE)		FL572	1-236-163-11	ENCAPSULATED COMPONENT (B,CP,VC,VC1,VC2)	
CNJ501	1-779-012-21	JACK, PIN 5P (DECODER/LINE-3 IN) (30:EE)				< IC >	
		< DIODE >		IC130	8-759-481-46	IC LB1943	
D100	8-719-048-26	DIODE GL528V1		IC160	8-759-248-87	IC MM1256XF-BE	
D110	8-719-200-82	DIODE 11ES2		IC161	8-759-454-78	IC 24LC08BT/SN	
D146	8-719-067-40	DIODE STZ6.8N-T146 (10,30,40:EXCEPT EE)		IC161	8-759-575-72	IC M24C08-WMMN6T	
D160	8-719-200-82	DIODE 11ES2		IC162	8-759-590-64	IC M37760MCA131GP (20:EX,UX,VP1/25/30:UX,CP,VC1/40:B,CP,VC1/45)	
D161	8-719-200-82	DIODE 11ES2					
D162	8-719-070-59	DIODE PDZ6.8B-115		IC162	8-759-590-66	IC M37760MCA133GP (20:VP2/30:VC2/40:VC2/X25)	
D163	8-719-070-59	DIODE PDZ6.8B-115		IC162	8-759-590-62	IC M37760M8A129GP (10:EE/30:EE/40:EE)	
D461	8-719-056-07	DIODE SLR-342MC3F (ON/STANDBY)		IC162	8-759-590-68	IC M37760MCA135GP (40:EG)	
D500	8-719-067-40	DIODE STZ6.8N-T146		IC162	8-759-590-65	IC M37760MCA132GP (10:AE2)	
D502	8-719-067-40	DIODE STZ6.8N-T146 (30:EE)		IC162	8-759-590-63	IC M37760MCA130GP (10:AE1)	
D504	8-719-067-40	DIODE STZ6.8N-T146		IC162	8-759-590-67	IC M37760MCA134GP (10:EG,X40,X10)	
D508	8-719-070-59	DIODE PDZ6.8B-115 (10,30,40:EXCEPT EE)		IC200	8-759-547-32	IC LA71560M-MPB	
D509	8-719-070-59	DIODE PDZ6.8B-115 (10:EE/30:EE/40:EE)		IC260	8-759-564-36	IC LA70011 (40,45,X40)	
D510	8-719-070-59	DIODE PDZ6.8B-115 (10,30,40:EXCEPT EE)		IC260	8-759-549-79	IC LA70001 (10,20,30,25,X10,X25)	
D511	8-719-070-59	DIODE PDZ6.8B-115 (10,30,40:EXCEPT EE)		IC320	8-759-499-30	IC BA7755AF-E2	
D512	8-719-977-40	DIODE UDZ-TE-17-13B (10,30,40:EXCEPT EE)		IC420	8-759-547-59	IC M35500BGP	
D513	8-719-067-40	DIODE STZ6.8N-T146 (10,30,40:EXCEPT EE)		IC460	8-742-042-00	HYB IC SBX1986-51	
D515	8-719-067-40	DIODE STZ6.8N-T146 (10,30,40:EXCEPT EE)		IC580	8-759-300-71	IC HD14053BFP (10/20/30:EE/EXCEPT 40:EE,EG/X40)	
D540	8-719-067-40	DIODE STZ6.8N-T146 (10/20/30:EE/EXCEPT 40:EE,EG/X40)		IC580	8-759-009-07	IC MC14053BFEL (10/20/30:EE/EXCEPT 40:EE,EG/X40)	
D542	8-719-067-40	DIODE STZ6.8N-T146 (B,CP,VC,VC1,VC2)		IC600	8-759-438-18	IC PQ12RD08	
D544	8-719-977-40	DIODE UDZ-TE-17-13B (10/20/30:EE/EXCEPT 40:EE,EG/X40)		IC601	8-759-438-18	IC PQ12RD08 (B,CP,VC,VC1,VC2)	
D570	8-719-070-59	DIODE PDZ6.8B-115 (10/20/30:EE/EXCEPT 40:EE,EG/X40)		IC850	8-759-484-61	IC SDA5650X-GEG (EXCEPT CP,EE,10,X40,X10)	
D571	8-719-067-40	DIODE STZ6.8N-T146 (10/20/30:EE/EXCEPT 40:EE,EG/X40)		IC870	8-759-988-36	IC BA14741F (30:EE)	
D575	8-719-067-40	DIODE STZ6.8N-T146 (B,CP,VC,VC1,VC2)		IC970	8-759-438-17	IC LA7337 (25:B/40:B)	
D590	8-719-988-61	DIODE 1SS355TE-17				< JUMPER RESISTOR >	
D591	8-719-988-61	DIODE 1SS355TE-17		JR001	1-216-295-91	SHORT	0
D600	8-719-988-61	DIODE 1SS355TE-17		JR002	1-216-296-91	SHORT	0
D601	8-719-988-61	DIODE 1SS355TE-17		JR003	1-216-296-91	SHORT	0
D602	8-719-070-56	DIODE PDZ5.1B-115		JR004	1-216-296-91	SHORT	0
D603	8-719-200-82	DIODE 11ES2 (B,CP,VC,VC1,VC2)		JR005	1-216-296-91	SHORT	0
D702	8-719-982-26	DIODE MTZJ-33B		JR006	1-216-296-91	SHORT	0
D750	8-719-200-82	DIODE 11ES2 (10,30,40:EXCEPT EE)		JR007	1-216-296-91	SHORT	0 (B,CP,VC,VC1,VC2)
D751	8-719-070-56	DIODE PDZ5.1B-115 (10:EE/30:EE/40:EE)		JR008	1-216-296-91	SHORT	0
D752	8-719-988-61	DIODE 1SS355TE-17 (10:EE/30:EE/40:EE)		JR009	1-216-296-91	SHORT	0 (10,30,40:EXCEPT EE)
D800	8-719-988-61	DIODE 1SS355TE-17 (10/30:EE/EXCEPT 40:EE/X10/X40)		JR010	1-216-296-91	SHORT	0 (10/20/30:EE/EXCEPT 40:EE,EG/X40)
				JR011	1-216-296-91	SHORT	0
				JR012	1-216-296-91	SHORT	0
				JR013	1-216-295-91	SHORT	0
				JR014	1-216-296-91	SHORT	0
				JR015	1-216-296-91	SHORT	0

MA-338

Ref. No.	Part No.	Description	Remarks	Ref. No.	Part No.	Description	Remarks
JR016	1-216-295-91	SHORT	0	JR074	1-216-295-91	SHORT	0
JR017	1-216-296-91	SHORT	0	JR075	1-216-296-91	SHORT	0
JR018	1-216-296-91	SHORT	0	JR076	1-216-296-91	SHORT	0
JR019	1-216-296-91	SHORT	0	JR077	1-216-296-91	SHORT	0
JR020	1-216-296-91	SHORT	0	JR079	1-216-296-91	SHORT	0
JR021	1-216-295-91	SHORT	0 (30:EE)	JR080	1-216-295-91	SHORT	0
JR022	1-216-296-91	SHORT	0 (10,30,40:EXCEPT EE)	JR081	1-216-295-91	SHORT	0
JR023	1-216-296-91	SHORT	0	JR082	1-216-295-91	SHORT	0
JR024	1-216-296-91	SHORT	0 (25:B/40:B)				(10/20/30:EE/EXCEPT40:EE,EG/X40)
JR025	1-216-296-91	SHORT	0	JR083	1-216-296-91	SHORT	0
JR026	1-216-295-91	SHORT	0 (10,30,40:EXCEPT EE)	JR084	1-216-295-91	SHORT	0
JR027	1-216-296-91	SHORT	0	JR085	1-216-295-91	SHORT	0
JR028	1-216-295-91	SHORT	0	JR086	1-216-295-91	SHORT	0 (25:B/40:B)
			(10/20/30:EE/EXCEPT 40:EE,EG/X40)	JR087	1-216-295-91	SHORT	0
JR029	1-216-295-91	SHORT	0 (10,30,40:EXCEPT EE)	JR088	1-216-296-91	SHORT	0
JR030	1-216-296-91	SHORT	0 (25:B/40:B)	JR089	1-216-296-91	SHORT	0
JR032	1-216-295-91	SHORT	0	JR090	1-216-296-91	SHORT	0
JR033	1-216-296-91	SHORT	0	JR091	1-216-296-91	SHORT	0
JR034	1-216-295-91	SHORT	0	JR092	1-216-296-91	SHORT	0
JR035	1-216-296-91	SHORT	0 (30:EE)	JR093	1-216-296-91	SHORT	0
JR036	1-216-296-91	SHORT	0 (30:EE)	JR094	1-216-295-91	SHORT	0
JR037	1-216-295-91	SHORT	0 (25:B/40:B)	JR095	1-216-295-91	SHORT	0
JR038	1-216-295-91	SHORT	0	JR096	1-216-296-91	SHORT	0
JR040	1-216-295-91	SHORT	0	JR097	1-216-295-91	SHORT	0
JR041	1-216-295-91	SHORT	0				< JUMPER RESISTOR >
JR042	1-216-296-91	SHORT	0	JS140	1-216-295-91	SHORT	0
JR043	1-216-296-91	SHORT	0	JS580	1-216-295-91	SHORT	0
JR044	1-216-296-91	SHORT	0				(10/20/30:EE/40:EE,EG/X10/X40)
JR045	1-216-295-91	SHORT	0	JS582	1-216-295-91	SHORT	0
JR046	1-216-296-91	SHORT	0	JS601	1-216-295-91	SHORT	0
			(10/20/30:EE/EXCEPT40:EE,EG/X40)				< COIL >
JR047	1-216-296-91	SHORT	0	L140	1-414-936-21	INDUCTOR	22uH
JR048	1-216-296-91	SHORT	0	L160	1-414-936-21	INDUCTOR	22uH
JR049	1-216-296-91	SHORT	0	L161	1-414-936-21	INDUCTOR	22uH
JR050	1-216-296-91	SHORT	0	L200	1-414-946-21	INDUCTOR	39uH
JR051	1-216-296-91	SHORT	0	L201	1-414-940-21	INDUCTOR	100uH
JR052	1-216-296-91	SHORT	0	L202	1-414-934-21	INDUCTOR	10uH
JR053	1-216-296-91	SHORT	0	L203	1-414-934-21	INDUCTOR	10uH
JR054	1-216-295-91	SHORT	0	L204	1-414-934-21	INDUCTOR	10uH
JR055	1-216-296-91	SHORT	0	L205	1-414-934-21	INDUCTOR	10uH
			(10/20/30:EE/EXCEPT40:EE,EG/X40)	L206	1-414-938-21	INDUCTOR	47uH (25:B/40:B)
JR056	1-216-296-91	SHORT	0	L270	1-414-940-21	INDUCTOR	100uH
JR057	1-216-296-91	SHORT	0	L300	1-414-940-21	INDUCTOR	100uH
JR058	1-216-296-91	SHORT	0	L460	1-414-938-21	INDUCTOR	47uH
JR059	1-216-296-91	SHORT	0	L510	1-414-940-21	INDUCTOR	100uH
JR060	1-216-296-91	SHORT	0	L580	1-414-940-21	INDUCTOR	100uH
JR061	1-216-296-91	SHORT	0				(25/30/40:B,CP,VC2,VC1/45/X25)
JR062	1-216-296-91	SHORT	0 (30,45:EE)	L600	1-414-939-21	INDUCTOR	68uH
JR063	1-216-296-91	SHORT	0 (30,45:EE)	L601	1-414-934-21	INDUCTOR	10uH
JR064	1-216-296-91	SHORT	0	L660	1-414-930-21	INDUCTOR	2.2uH
JR065	1-216-296-91	SHORT	0 (10,30,40:EXCEPT EE)	L661	1-414-936-21	INDUCTOR	22uH (B,EE,EG)
JR066	1-216-296-91	SHORT	0	L662	1-414-936-21	INDUCTOR	22uH
			(10/20/30:EE/EXCEPT 40:EE,EG/X40)	L663	1-414-936-21	INDUCTOR	22uH
JR067	1-216-295-91	SHORT	0 (30:EE)	L701	1-414-930-21	INDUCTOR	2.2uH
JR068	1-216-295-91	SHORT	0	L750	1-414-930-21	INDUCTOR	2.2uH
			(10/20/30:EE/EXCEPT 40:EE,EG/X40)	L970	1-414-933-21	INDUCTOR	6.8uH (25:B/40:B)
JR070	1-216-296-91	SHORT	0	L971	1-414-945-21	INDUCTOR	27uH (25:B/40:B)
JR071	1-216-296-91	SHORT	0				
JR072	1-216-296-91	SHORT	0				
JR073	1-216-296-91	SHORT	0				

Ref. No.	Part No.	Description	Remarks	Ref. No.	Part No.	Description	Remarks
L972	1-414-938-21	INDUCTOR	47uH(25:B/40:B)	Q606	8-729-043-29	TRANSISTOR	PDTC144EK-115 (10,30,40:EXCEPT EE)
L973	1-414-938-21	INDUCTOR	47uH(25:B/40:B)	Q607	8-729-804-41	TRANSISTOR	2SB1122-ST-TD (B,CP,VC,VC1,VC2)
L975	1-414-934-21	INDUCTOR	10uH(25:B/40:B)	Q608	8-729-043-29	TRANSISTOR	PDTC144EK-115 (B,CP,VC,VC1,VC2)
< FLUORESCENT INDICATOR >				Q611	8-729-106-68	TRANSISTOR	2SD1615A-GP
ND420	1-517-832-11	INDICATOR TUBE, FLUORESCENT	(10/30:EE/EXCEPT 40:EE,EG/X10/X40)	Q660	8-729-216-22	TRANSISTOR	2SA1162-G
ND420	1-517-833-11	INDICATOR TUBE, FLUORESCENT	(10/30:EE/40:EE,EG/X10/X40)	Q661	8-729-216-22	TRANSISTOR	2SA1162-G
< PHOTO INTERRUPTER >				Q750	8-729-012-31	TRANSISTOR	2SC4040-TL2-Q (10:EE/30:EE/40:EE)
PH100	8-749-013-23	PHOTO INTERRUPTER GP3S120		Q751	8-729-043-29	TRANSISTOR	PDTC144EK-115 (10,30,40:EXCEPT EE)
PH101	8-749-013-23	PHOTO INTERRUPTER GP3S120		Q752	8-729-216-22	TRANSISTOR	2SA1162-G (10,30,40:EXCEPT EE)
< IC LINK >				Q800	8-729-216-22	TRANSISTOR	2SA1162-G (10/30:EE/EXCEPT 40:EE/X10/X40)
△ PS120	1-533-586-31	LINK, IC		Q801	8-729-422-33	TRANSISTOR	2PD601AR-115 (10/30:EE/EXCEPT 40:EE/X10/X40)
△ PS600	1-533-593-11	LINK, IC		Q802	8-729-422-33	TRANSISTOR	2PD601AR-115 (10/30:EE/EXCEPT 40:EE/X10/X40)
△ PS601	1-533-589-21	LINK, IC		Q803	8-729-422-33	TRANSISTOR	2PD601AR-115 (10/30:EE/EXCEPT 40:EE/X10/X40)
△ PS602	1-533-586-31	LINK, IC	315mA 491.315 (B,CP,VC,VC1,VC2)	Q804	8-729-043-29	TRANSISTOR	PDTC144EK-115 (10/30:EE/EXCEPT 40:EE/X10/X40)
< TRANSISTOR >				Q850	8-729-216-22	TRANSISTOR	2SA1162-G (EXCEPT CP,EE,10,X10,X40)
Q100	8-729-043-84	TRANSISTOR	PT380F3	Q870	8-729-043-29	TRANSISTOR	PDTC144EK-115 (30:EE)
Q100	8-729-047-02	TRANSISTOR	RPT-37PBT32L	Q871	8-729-422-33	TRANSISTOR	2PD601AR-115 (30:EE)
Q101	8-729-043-84	TRANSISTOR	PT380F3	Q970	8-729-216-22	TRANSISTOR	2SA1162-G (25:B/40:B)
Q101	8-729-047-02	TRANSISTOR	RPT-37PBT32L	Q972	8-729-043-32	TRANSISTOR	PDTA114EK-115 (25:B/40:B)
Q102	8-729-281-53	TRANSISTOR	2SC1815-GR	Q973	8-729-422-33	TRANSISTOR	2PD601AR-115 (25:B/40:B)
Q200	8-729-422-33	TRANSISTOR	2PD601AR-115	Q974	8-729-422-33	TRANSISTOR	2PD601AR-115 (25:B/40:B)
Q201	8-729-422-33	TRANSISTOR	2PD601AR-115	Q975	8-729-043-32	TRANSISTOR	PDTA114EK-115 (25:B/40:B)
Q202	8-729-422-33	TRANSISTOR	2PD601AR-115	Q976	8-729-043-29	TRANSISTOR	PDTC144EK-115 (25:B/40:B)
Q203	8-729-216-22	TRANSISTOR	2SA1162-G	< RESISTOR >			
Q204	8-729-043-29	TRANSISTOR	PDTC144EK-115 (25:B/40:B)	R100	1-216-089-91	RES,CHIP	47K 5% 1/10W
Q320	8-729-804-41	TRANSISTOR	2SB1122-S	R101	1-249-413-11	CARBON	470 5% 1/4W F
Q321	8-729-802-91	TRANSISTOR	2SD879	R102	1-216-089-91	RES,CHIP	47K 5% 1/10W
Q461	8-729-043-29	TRANSISTOR	PDTC144EK-115	R103	1-216-081-00	METAL CHIP	22K 5% 1/10W
Q501	8-729-043-32	TRANSISTOR	PDTA114EK-115 (10,30,40:EXCEPT EE)	R104	1-216-049-91	RES,CHIP	1K 5% 1/10W
Q502	8-729-043-29	TRANSISTOR	PDTC144EK-115 (10,30,40:EXCEPT EE)	R105	1-216-057-00	METAL CHIP	2.2K 5% 1/10W
Q510	8-729-216-22	TRANSISTOR	2SA1162-G	R106	1-249-400-11	CARBON	39 5% 1/4W F
Q540	8-729-216-22	TRANSISTOR	2SA1162-G (B,CP,VC,VC1,VC2)	R107	1-249-400-11	CARBON	39 5% 1/4W F
Q541	8-729-216-22	TRANSISTOR	2SA1162-G (B,CP,VC,VC1,VC2)	R108	1-216-081-00	METAL CHIP	22K 5% 1/10W
Q580	8-729-043-29	TRANSISTOR	PDTC144EK-115 (10/20/30:EE/EXCEPT 40:EE,EG/X40)	R114	1-216-089-91	RES,CHIP	47K 5% 1/10W
Q581	8-729-043-29	TRANSISTOR	PDTC144EK-115 (10/20/30:EE/EXCEPT 40:EE,EG/X40)	R115	1-216-089-91	RES,CHIP	47K 5% 1/10W
Q582	8-729-043-29	TRANSISTOR	PDTC144EK-115 (10/20/30:EE/EXCEPT 40:EE,EG/X40)	R120	1-216-089-91	RES,CHIP	47K 5% 1/10W
Q583	8-729-422-33	TRANSISTOR	2PD601AR-115 (25/30/40:B,CP,VC2,VC1/45/X25)	R121	1-216-089-91	RES,CHIP	47K 5% 1/10W
Q590	8-729-422-33	TRANSISTOR	2PD601AR-115 (30:EE)	R123	1-216-065-91	RES,CHIP	4.7K 5% 1/10W
Q591	8-729-422-33	TRANSISTOR	2PD601AR-115	R124	1-216-041-00	METAL CHIP	470 5% 1/10W
Q600	8-729-018-99	TRANSISTOR	2SD2394-F	R130	1-216-077-00	METAL CHIP	15K 5% 1/10W
Q601	8-729-140-93	TRANSISTOR	2SB733-34	R132	1-216-041-00	METAL CHIP	470 5% 1/10W
Q602	8-729-140-96	TRANSISTOR	2SD774-34 (10,30,40:EXCEPT EE)	R133	1-216-089-91	RES,CHIP	47K 5% 1/10W
Q603	8-729-422-33	TRANSISTOR	2PD601AR-115	R142	1-216-051-00	METAL CHIP	1.2K 5% 1/10W
Q604	8-729-119-79	TRANSISTOR	2SC2785-FEK	R143	1-216-065-91	RES,CHIP	4.7K 5% 1/10W
Q605	8-729-043-32	TRANSISTOR	PDTA114EK-115 (10,30,40:EXCEPT EE)				

<p>Note : The components identified by mark △ or dotted line with mark △ are critical for safety. Replace only with part number specified.</p>	<p>Note : Les composants identifiés par une marque △ sont critiques pour la sécurité. Ne les remplacer que par une pièce portant le numéro spécifié.</p>
---	---

MA-338

Ref. No.	Part No.	Description	Remarks		
R160	1-216-067-00	METAL CHIP	5.6K	5%	1/10W (20:EX,U/30:UX/45:UX)
R160	1-216-053-00	METAL CHIP	1.5K	5%	1/10W (30:EE/40:CP,VC1/45:CP,VC)
R160	1-216-071-00	METAL CHIP	8.2K	5%	1/10W (25:B/40:B)
R160	1-216-085-00	METAL CHIP	33K	5%	1/10W (10:AE2/20:VP2/30:VC2/40:VC2/X25)
R160	1-216-061-00	METAL CHIP	3.3K	5%	1/10W (40:EE)
R160	1-216-075-00	METAL CHIP	12K	5%	1/10W (10:EG/40:EG,X40,X10)
R160	1-216-295-91	SHORT	0		(10:AE1,EE/20:VP1/25:CP,VC/30:CP,VC1)
R161	1-216-067-00	METAL CHIP	5.6K	5%	1/10W (30:CP,VC2/40:EG/45:UX,VC)
R161	1-216-061-00	METAL CHIP	3.3K	5%	1/10W (25:VC/30:UX/40:B/45:CP/X25)
R161	1-216-295-91	SHORT	0		(10:AE2,EG/20:UX/25:B,CP/40:CP/X10)
R161	1-216-071-00	METAL CHIP	8.2K	5%	1/10W (30:VC1/40:VC2/X40)
R161	1-216-053-00	METAL CHIP	1.5K	5%	1/10W (20:EX,VP1,VP2/40:VC1)
R161	1-216-075-00	METAL CHIP	12K	5%	1/10W (10:AE1)
R162	1-216-073-00	METAL CHIP	10K	5%	1/10W
R163	1-216-073-00	METAL CHIP	10K	5%	1/10W
R164	1-216-073-00	METAL CHIP	10K	5%	1/10W
R167	1-216-073-00	METAL CHIP	10K	5%	1/10W
R168	1-216-101-00	METAL CHIP	150K	5%	1/10W
R169	1-216-113-00	METAL CHIP	470K	5%	1/10W
R170	1-216-061-00	METAL CHIP	3.3K	5%	1/10W
R171	1-216-073-00	METAL CHIP	10K	5%	1/10W
R173	1-216-089-91	RES,CHIP	47K	5%	1/10W
R176	1-216-037-00	METAL CHIP	330	5%	1/10W
R177	1-216-041-00	METAL CHIP	470	5%	1/10W
R178	1-216-041-00	METAL CHIP	470	5%	1/10W
R179	1-216-041-00	METAL CHIP	470	5%	1/10W
R180	1-216-061-00	METAL CHIP	3.3K	5%	1/10W
R181	1-216-061-00	METAL CHIP	3.3K	5%	1/10W
R182	1-216-041-00	METAL CHIP	470	5%	1/10W
R183	1-216-041-00	METAL CHIP	470	5%	1/10W
R184	1-216-295-91	SHORT	0		
R185	1-216-295-91	SHORT	0		
R189	1-216-049-91	RES,CHIP	1K	5%	1/10W
R195	1-216-022-00	METAL CHIP	75	5%	1/10W
R197	1-216-022-00	METAL CHIP	75	5%	1/10W
R198	1-216-081-00	METAL CHIP	22K	5%	1/10W
R199	1-216-093-91	RES,CHIP	68K	5%	1/10W (10:EE,EG/20:25/30/40/45/X10/X40)
R200	1-216-073-00	METAL CHIP	10K	5%	1/10W
R203	1-216-055-00	METAL CHIP	1.8K	5%	1/10W
R204	1-216-037-00	METAL CHIP	330	5%	1/10W
R205	1-216-037-00	METAL CHIP	330	5%	1/10W
R206	1-216-045-00	METAL CHIP	680	5%	1/10W (40,45,X40)
R206	1-216-047-91	RES,CHIP	820	5%	1/10W (10/20/25/30/X10/X25)
R207	1-216-059-00	METAL CHIP	2.7K	5%	1/10W (40,45,X40)
R207	1-216-053-00	METAL CHIP	1.5K	5%	1/10W (10/20/25/30/X10/X25)

Ref. No.	Part No.	Description	Remarks		
R208	1-216-065-91	RES,CHIP	4.7K	5%	1/10W
R209	1-216-055-00	METAL CHIP	1.8K	5%	1/10W (40,45,X40)
R209	1-216-077-00	METAL CHIP	15K	5%	1/10W (10/20/25/30/X10/X25)
R210	1-216-051-00	METAL CHIP	1.2K	5%	1/10W
R211	1-216-071-00	METAL CHIP	8.2K	5%	1/10W
R212	1-216-051-00	METAL CHIP	1.2K	5%	1/10W
R213	1-216-049-91	RES,CHIP	1K	5%	1/10W
R214	1-216-049-91	RES,CHIP	1K	5%	1/10W
R215	1-216-025-91	RES,CHIP	100	5%	1/10W
R216	1-216-109-00	METAL CHIP	330K	5%	1/10W (40,45,X40)
R216	1-216-117-00	METAL CHIP	680K	5%	1/10W (10/20/25/30/X10/X25)
R217	1-216-025-91	RES,CHIP	100	5%	1/10W (B,CP,VC,VC1,VC2)
R218	1-216-295-91	SHORT	0		
R219	1-216-025-91	RES,CHIP	100	5%	1/10W
R220	1-216-049-91	RES,CHIP	1K	5%	1/10W
R221	1-216-017-91	RES,CHIP	47	5%	1/10W
R222	1-216-017-91	RES,CHIP	47	5%	1/10W (30,45)
R223	1-216-017-91	RES,CHIP	47	5%	1/10W (10/20/30:EE/EXCEPT 40:EE,EG/X40)
R224	1-216-057-00	METAL CHIP	2.2K	5%	1/10W
R225	1-216-057-00	METAL CHIP	2.2K	5%	1/10W
R226	1-216-055-00	METAL CHIP	1.8K	5%	1/10W
R227	1-216-295-91	SHORT	0		
R228	1-216-295-91	SHORT	0		(25:B/40:B)
R232	1-216-055-00	METAL CHIP	1.8K	5%	1/10W (10/20/25/30/X10/X25)
R233	1-216-065-91	RES,CHIP	4.7K	5%	1/10W (25:B/40:B)
R270	1-216-043-91	RES,CHIP	560	5%	1/10W (40,45,X40)
R271	1-216-043-91	RES,CHIP	560	5%	1/10W
R272	1-216-057-00	METAL CHIP	2.2K	5%	1/10W (40,45,X40)
R272	1-216-053-00	METAL CHIP	1.5K	5%	1/10W (20:EX,U/25:CP/VC30:EXCEPT EE/X25)
R272	1-216-049-91	RES,CHIP	1K	5%	1/10W (10/20:VP1,VP2/25:B/30:EE/X10)
R273	1-216-295-91	SHORT	0		
R274	1-216-065-91	RES,CHIP	4.7K	5%	1/10W (40,45,X40)
R274	1-216-067-00	METAL CHIP	5.6K	5%	1/10W (10/20/25/30/X10/X25)
R276	1-216-069-00	METAL CHIP	6.8K	5%	1/10W
R277	1-216-081-00	METAL CHIP	22K	5%	1/10W
R278	1-216-081-00	METAL CHIP	22K	5%	1/10W
R279	1-216-081-00	METAL CHIP	22K	5%	1/10W
R280	1-216-097-91	RES,CHIP	100K	5%	1/10W
R283	1-216-295-91	SHORT	0		
R284	1-216-295-91	SHORT	0		
R300	1-216-089-91	RES,CHIP	47K	5%	1/10W
R301	1-216-089-91	RES,CHIP	47K	5%	1/10W
R303	1-216-063-91	RES,CHIP	3.9K	5%	1/10W
R305	1-216-071-00	METAL CHIP	8.2K	5%	1/10W
R306	1-216-053-00	METAL CHIP	1.5K	5%	1/10W

Ref. No.	Part No.	Description	Quantity	Material	Remarks	Ref. No.	Part No.	Description	Quantity	Material	Remarks
R311	1-216-035-00	METAL CHIP	270	5%	1/10W	R515	1-216-049-91	RES,CHIP	1K	5%	1/10W
R312	1-216-109-00	METAL CHIP	330K	5%	1/10W						(10,30,40:EXCEPT EE)
R313	1-216-047-91	RES,CHIP	820	5%	1/10W	R516	1-216-065-91	RES,CHIP	4.7K	5%	1/10W
R314	1-216-073-00	METAL CHIP	10K	5%	1/10W						(10,30,40:EXCEPT EE)
R318	1-216-067-00	METAL CHIP	5.6K	5%	1/10W	R517	1-216-022-00	METAL CHIP	75	5%	1/10W
						R541	1-216-025-91	RES,CHIP	100	5%	1/10W
R319	1-216-093-91	RES,CHIP	68K	5%	1/10W						(B,CP,VC,VC1,VC2)
R320	1-216-129-00	METAL CHIP	2.2M	5%	1/10W	R542	1-249-408-11	CARBON	180	5%	1/4W F
R321	1-216-051-00	METAL CHIP	1.2K	5%	1/10W						(B,CP,VC,VC1,VC2)
R322	1-216-079-00	METAL CHIP	18K	5%	1/10W						
R323	1-216-069-00	METAL CHIP	6.8K	5%	1/10W	R545	1-216-085-00	METAL CHIP	33K	5%	1/10W
											(B,CP,VC,VC1,VC2)
R324	1-216-089-91	RES,CHIP	47K	5%	1/10W	R546	1-216-089-91	RES,CHIP	47K	5%	1/10W
R325	1-216-067-00	METAL CHIP	5.6K	5%	1/10W						(B,CP,VC,VC1,VC2)
						R547	1-216-049-91	RES,CHIP	1K	5%	1/10W
R326	1-216-093-91	RES,CHIP	68K	5%	1/10W						(B,CP,VC,VC1,VC2)
						R548	1-216-022-00	METAL CHIP	75	5%	1/10W
R327	1-216-067-00	METAL CHIP	5.6K	5%	1/10W						(10/20/30:EE/EXCEPT 40:EE,EG/X40)
R328	1-216-093-91	RES,CHIP	68K	5%	1/10W	R549	1-216-022-00	METAL CHIP	75	5%	1/10W
											(B,CP,VC,VC1,VC2)
R329	1-216-031-00	METAL CHIP	180	5%	1/10W						
R330	1-216-017-91	RES,CHIP	47	5%	1/10W	R550	1-216-022-00	METAL CHIP	75	5%	1/10W
R331	1-216-063-91	RES,CHIP	3.9K	5%	1/10W						(B,CP,VC,VC1,VC2)
R332	1-216-075-00	METAL CHIP	12K	5%	1/10W	R551	1-216-022-00	METAL CHIP	75	5%	1/10W
R333	1-216-079-00	METAL CHIP	18K	5%	1/10W						(B,CP,VC,VC1,VC2)
R334	1-217-671-11	METAL CHIP	1	5%	1/10W	R570	1-216-041-00	METAL CHIP	470	5%	1/10W
R335	1-216-081-00	METAL CHIP	22K	5%	1/10W						(10/20/30:EE/EXCEPT 40:EE,EG/X40)
R420	1-216-295-91	SHORT	0			R571	1-216-041-00	METAL CHIP	470	5%	1/10W
R421	1-216-295-91	SHORT	0								(10/20/30:EE/EXCEPT 40:EE,EG/X40)
R422	1-216-049-91	RES,CHIP	1K	5%	1/10W	R572	1-216-041-00	METAL CHIP	470	5%	1/10W
											(B,CP,VC,VC1,VC2)
R423	1-216-295-91	SHORT	0								
R426	1-216-041-00	METAL CHIP	470	5%	1/10W	R574	1-216-097-91	RES,CHIP	100K	5%	1/10W
											(B,CP,VC,VC1,VC2)
R461	1-216-073-00	METAL CHIP	10K	5%	1/10W	R580	1-216-065-91	RES,CHIP	4.7K	5%	1/10W
R463	1-216-073-00	METAL CHIP	10K	5%	1/10W	R581	1-216-049-91	RES,CHIP	1K	5%	1/10W
R464	1-216-037-00	METAL CHIP	330	5%	1/10W	R582	1-216-073-00	METAL CHIP	10K	5%	1/10W
											(10/20/30:EE/EXCEPT 40:EE,EG/X40)
R466	1-216-037-00	METAL CHIP	330	5%	1/10W	R583	1-216-073-00	METAL CHIP	10K	5%	1/10W
R467	1-216-049-91	RES,CHIP	1K	5%	1/10W						(10/20/30:EE/EXCEPT 40:EE,EG/X40)
R468	1-216-057-00	METAL CHIP	2.2K	5%	1/10W	R584	1-216-073-00	METAL CHIP	10K	5%	1/10W
R469	1-216-053-00	METAL CHIP	1.5K	5%	1/10W						(10/20/30:EE/EXCEPT 40:EE,EG/X40)
R470	1-216-061-00	METAL CHIP	3.3K	5%	1/10W	R585	1-216-097-91	RES,CHIP	100K	5%	1/10W
											(10/20/30:EE/EXCEPT 40:EE,EG/X40)
R471	1-216-057-00	METAL CHIP	2.2K	5%	1/10W	R586	1-216-097-91	RES,CHIP	100K	5%	1/10W
R472	1-216-065-91	RES,CHIP	4.7K	5%	1/10W						(10/20/30:EE/EXCEPT 40:EE,EG/X40)
R473	1-216-061-00	METAL CHIP	3.3K	5%	1/10W	R587	1-216-097-91	RES,CHIP	100K	5%	1/10W
R474	1-216-081-00	METAL CHIP	22K	5%	1/10W						(10/20/30:EE/EXCEPT 40:EE,EG/X40)
R475	1-216-065-91	RES,CHIP	4.7K	5%	1/10W	R588	1-216-097-91	RES,CHIP	100K	5%	1/10W
											(45/40:B,CP,VC2,VC1/30/25/X25)
R500	1-216-041-00	METAL CHIP	470	5%	1/10W						
R501	1-216-041-00	METAL CHIP	470	5%	1/10W	R589	1-216-097-91	RES,CHIP	100K	5%	1/10W
R502	1-216-041-00	METAL CHIP	470	5%	1/10W						(10/20/30:EE/EXCEPT 40:EE,EG/X40)
						R590	1-216-049-91	RES,CHIP	1K	5%	1/10W
R502	1-216-065-91	RES,CHIP	4.7K	5%	1/10W	R591	1-216-049-91	RES,CHIP	1K	5%	1/10W
											(30:EE)
R503	1-216-065-91	RES,CHIP	4.7K	5%	1/10W	R592	1-216-073-00	METAL CHIP	10K	5%	1/10W
											(25/30/40:B,CP,VC1,VC2/45/X25)
						R593	1-216-057-00	METAL CHIP	2.2K	5%	1/10W
											(25/30/40:B,CP,VC1,VC2/45/X25)
R510	1-249-407-11	CARBON	150	5%	1/4W F						
						R594	1-216-077-00	METAL CHIP	15K	5%	1/10W
R510	1-249-408-11	CARBON	180	5%	1/4W F						(25/30/40:B,CP,VC1,VC2/45/X25)
						R595	1-216-295-91	SHORT	0	(EXCEPT 30,45:EE)	
R511	1-249-407-11	CARBON	150	5%	1/4W F	R597	1-216-041-00	METAL CHIP	470	5%	1/10W
R512	1-216-022-00	METAL CHIP	75	5%	1/10W	R598	1-216-041-00	METAL CHIP	470	5%	1/10W
R514	1-216-037-00	METAL CHIP	330	5%	1/10W						(30:EE)
						R600	1-249-417-11	CARBON	1K	5%	1/4W F

MA-338

Ref. No.	Part No.	Description	Quantity	Material	Dimensions	Remarks
R601	1-249-417-11	CARBON	1K	5%	1/4W F	
R602	1-216-089-91	RES,CHIP	47K	5%	1/10W	(10,30,40:EXCEPT EE)
R603	1-216-452-11	METAL OXIDE	180	5%	2W F	
R604	1-216-065-91	RES,CHIP	4.7K	5%	1/10W	
R605	1-216-065-91	RES,CHIP	4.7K	5%	1/10W	
R606	1-216-069-00	METAL CHIP	6.8K	5%	1/10W	(10,30,40:EXCEPT EE)
R607	1-216-053-00	METAL CHIP	1.5K	5%	1/10W	
R608	1-249-414-11	CARBON	560	5%	1/4W F	
R609	1-247-815-91	CARBON	220	5%	1/4W	
R610	1-247-815-91	CARBON	220	5%	1/4W	
R611	1-216-049-91	RES,CHIP	1K	5%	1/10W	(B,CP,VC,VC1,VC2)
R612	1-216-089-91	RES,CHIP	47K	5%	1/10W	
R613	1-215-907-11	METAL OXIDE	22	5%	3W F	
R614	1-215-857-11	METAL OXIDE	10	5%	1W F	
R615	1-216-049-91	RES,CHIP	1K	5%	1/10W	(B,CP,VC,VC1,VC2)
R616	1-216-057-00	METAL CHIP	2.2K	5%	1/10W	
R617	1-216-049-91	RES,CHIP	1K	5%	1/10W	(B,CP,VC,VC1,VC2)
R618	1-216-055-00	METAL CHIP	1.8K	5%	1/10W	(B,CP,VC,VC1,VC2)
R622	1-260-073-11	CARBON	5.6	5%	1/2W	
R623	1-260-073-11	CARBON	5.6	5%	1/2W	
R660	1-216-049-91	RES,CHIP	1K	5%	1/10W	
R661	1-216-121-91	RES,CHIP	1M	5%	1/10W	
R662	1-216-041-00	METAL CHIP	470	5%	1/10W	
R663	1-216-053-00	METAL CHIP	1.5K	5%	1/10W	
R666	1-216-295-91	SHORT	0			
R667	1-216-037-00	METAL CHIP	330	5%	1/10W	
R668	1-216-025-91	RES,CHIP	100	5%	1/10W	
R669	1-216-025-91	RES,CHIP	100	5%	1/10W	
R670	1-216-041-00	METAL CHIP	470	5%	1/10W	
R671	1-216-295-91	SHORT	0			
R672	1-216-049-91	RES,CHIP	1K	5%	1/10W	(B,EE,EG)
R702	1-216-295-91	SHORT	0			
R704	1-216-041-00	METAL CHIP	470	5%	1/10W	
R705	1-216-041-00	METAL CHIP	470	5%	1/10W	
△R711	1-212-895-00	FUSIBLE	390	5%	1/4W F	
R713	1-216-025-91	RES,CHIP	100	5%	1/10W	
R714	1-216-113-00	METAL CHIP	470K	5%	1/10W	
R731	1-216-041-00	METAL CHIP	470	5%	1/10W	(EXCEPT UX,EE,EG)
R733	1-216-041-00	METAL CHIP	470	5%	1/10W	(EXCEPT UX)
R751	1-216-009-91	RES,CHIP	22	5%	1/10W	(10:EE/30:EE/40:EE)
R754	1-216-041-00	METAL CHIP	470	5%	1/10W	
R755	1-216-041-00	METAL CHIP	470	5%	1/10W	
R756	1-216-073-00	METAL CHIP	10K	5%	1/10W	(10,30,40:EXCEPT EE)
R757	1-216-049-91	RES,CHIP	1K	5%	1/10W	(10,30,40:EXCEPT EE)
R800	1-216-101-00	METAL CHIP	150K	5%	1/10W	(10/30:EE/EXCEPT 40:EE/X10/X40)

Ref. No.	Part No.	Description	Quantity	Material	Dimensions	Remarks
R801	1-216-073-00	METAL CHIP	10K	5%	1/10W	(10/30:EE/EXCEPT 40:EE/X10/X40)
R802	1-216-073-00	METAL CHIP	10K	5%	1/10W	(10/30:EE/EXCEPT 40:EE/X10/X40)
R803	1-216-081-00	METAL CHIP	22K	5%	1/10W	(10/30:EE/EXCEPT 40:EE/X10/X40)
R804	1-216-073-00	METAL CHIP	10K	5%	1/10W	(10/30:EE/EXCEPT 40:EE/X10/X40)
R805	1-216-073-00	METAL CHIP	10K	5%	1/10W	(10/30:EE/EXCEPT 40:EE/X10/X40)
R806	1-216-073-00	METAL CHIP	10K	5%	1/10W	(10/30:EE/EXCEPT 40:EE/X10/X40)
R807	1-216-085-00	METAL CHIP	33K	5%	1/10W	(10/30:EE/EXCEPT 40:EE/X10/X40)
R813	1-216-073-00	METAL CHIP	10K	5%	1/10W	(10/30:EE/EXCEPT 40:EE/X10/X40)
R850	1-216-025-91	RES,CHIP	100	5%	1/10W	(EXCEPT CP,EE,10,X10,X40)
R851	1-216-077-00	METAL CHIP	15K	5%	1/10W	(EXCEPT CP,EE,10,X10,X40)
R852	1-216-081-00	METAL CHIP	22K	5%	1/10W	(EXCEPT CP,EE,10,X10,X40)
R853	1-216-049-91	RES,CHIP	1K	5%	1/10W	(EXCEPT CP,EE,10,X10,X40)
R856	1-216-097-91	RES,CHIP	100K	5%	1/10W	(EXCEPT CP,EE,10,X10,X40)
R857	1-216-069-00	METAL CHIP	6.8K	5%	1/10W	(EXCEPT CP,EE,10,X10,X40)
R858	1-216-069-00	METAL CHIP	6.8K	5%	1/10W	(EXCEPT CP,EE,10,X10,X40)
R859	1-216-123-11	METAL CHIP	1.2M	5%	1/10W	(EXCEPT CP,EE,10,X10,X40)
R860	1-216-123-11	METAL CHIP	1.2M	5%	1/10W	(EXCEPT CP,EE,10,X10,X40)
R861	1-216-117-00	METAL CHIP	680K	5%	1/10W	(EXCEPT CP,EE,10,X10,X40)
R862	1-216-057-00	METAL CHIP	2.2K	5%	1/10W	(EXCEPT CP,EE,10,X10,X40)
R870	1-216-097-91	RES,CHIP	100K	5%	1/10W	(30:EE)
R871	1-216-073-00	METAL CHIP	10K	5%	1/10W	(30:EE)
R872	1-216-073-00	METAL CHIP	10K	5%	1/10W	(30:EE)
R873	1-216-049-91	RES,CHIP	1K	5%	1/10W	(30:EE)
R874	1-216-033-00	METAL CHIP	220	5%	1/10W	(30:EE)
R875	1-216-077-00	METAL CHIP	15K	5%	1/10W	(30:EE)
R876	1-216-073-00	METAL CHIP	10K	5%	1/10W	(30:EE)
R877	1-216-077-00	METAL CHIP	15K	5%	1/10W	(30:EE)
R878	1-216-089-91	RES,CHIP	47K	5%	1/10W	(30:EE)
R879	1-216-073-00	METAL CHIP	10K	5%	1/10W	(30:EE)
R880	1-216-081-00	METAL CHIP	22K	5%	1/10W	(30:EE)

Note :
 The components identified by mark △ or dotted line with mark △ are critical for safety. Replace only with part number specified.

Note :
 Les composants identifiés par une marque △ sont critiques pour la sécurité. Ne les remplacer que par une pièce portant le numéro spécifié.

Ref. No.	Part No.	Description	Remarks	Ref. No.	Part No.	Description	Remarks
R881	1-216-081-00	METAL CHIP	22K 5% 1/10W (30:EE)	R993	1-216-071-00	METAL CHIP	8.2K 5% 1/10W (25:B/40:B)
R882	1-216-081-00	METAL CHIP	22K 5% 1/10W (30:EE)	R994	1-216-689-11	METAL CHIP	39K 0.5% 1/10W (25:B/40:B)
R883	1-216-089-91	RES,CHIP	47K 5% 1/10W (30:EE)	R995	1-216-073-00	METAL CHIP	10K 5% 1/10W (25:B/40:B)
R884	1-216-089-91	RES,CHIP	47K 5% 1/10W (30:EE)	R996	1-216-689-11	METAL CHIP	39K 0.5% 1/10W (25:B/40:B)
R885	1-216-073-00	METAL CHIP	10K 5% 1/10W (30:EE)	R997	1-216-073-00	METAL CHIP	10K 5% 1/10W (25:B/40:B)
R886	1-216-033-00	METAL CHIP	220 5% 1/10W (30:EE)	R998	1-216-073-00	METAL CHIP	10K 5% 1/10W (25:B/40:B)
R887	1-216-081-00	METAL CHIP	22K 5% 1/10W (30:EE)	R999	1-216-295-91	SHORT	0 (25:B/40:B)
R888	1-216-097-91	RES,CHIP	100K 5% 1/10W (30:EE)			< SWITCH >	
R968	1-216-101-00	METAL CHIP	150K 5% 1/10W (25:B/40:B)	S100	1-771-155-11	SWITCH, ROTARY (MECHANISM MODE)	
				S101	1-762-108-11	SWITCH, PUSH (1 KEY) (REC PROOF)	
				S160	1-571-588-11	SWITCH, SLIDE (ON PAL TV/NTSC 4.43) (EXCEPT 10:AE1,AE2)	
R969	1-216-069-00	METAL CHIP	6.8K 5% 1/10W (25:B/40:B)	S460	1-771-574-21	SWITCH, TACTILE (POWER)	
R970	1-216-085-00	METAL CHIP	33K 5% 1/10W (25:B/40:B)	S461	1-771-574-21	SWITCH, TACTILE (EJECT)	
R971	1-216-085-00	METAL CHIP	33K 5% 1/10W (25:B/40:B)	S462	1-771-574-21	SWITCH, TACTILE (PAUSE)	
R972	1-216-083-00	METAL CHIP	27K 5% 1/10W (25:B/40:B)	S463	1-771-574-21	SWITCH, TACTILE (REC)	
R973	1-216-105-91	RES,CHIP	220K 5% 1/10W (25:B/40:B)	S464	1-771-574-21	SWITCH, TACTILE (PROGRAM-)	
				S465	1-771-574-21	SWITCH, TACTILE(AUTO SET UP/RF CHANNEL)	
				S466	1-771-574-21	SWITCH, TACTILE(PROGRAM+)	
						< TRANSFORMER >	
R974	1-216-081-00	METAL CHIP	22K 5% 1/10W (25:B/40:B)	T320	1-431-097-11	TRANSFORMER, BIAS OSCILLATION	
R975	1-216-295-91	SHORT	0 (25:B/40:B)			< TUNER >	
R976	1-216-059-00	METAL CHIP	2.7K 5% 1/10W (25:B/40:B)	TU700	1-693-433-11	TUNER, IF (BTF-3MC404) (EXCEPT UX,B,VP1,VP2,EE,EG)	
R977	1-216-089-91	RES,CHIP	47K 5% 1/10W (25:B/40:B)	TU700	1-693-435-11	TUNER, IF (BTF-3MC445) (25:B/40:B)	
R978	1-216-071-00	METAL CHIP	8.2K 5% 1/10W (25:B/40:B)	TU700	1-693-431-11	TUNER, IF (BTF-2MC421) (10:AE1,AE2/20:VP1,VP2/25:CP,VC/X25)	
R979	1-216-073-00	METAL CHIP	10K 5% 1/10W (25:B/40:B)	TU701	1-693-434-11	TUNER, IF (BTF-3MU604) (20:UX/30:UX/45:UX)	
R980	1-216-097-91	RES,CHIP	100K 5% 1/10W (25:B/40:B)	TU701	1-693-431-11	TUNER, IF (BTF-2MC421) (10:EE,EG/30:EE/40:EE,EG,X10,X40)	
R981	1-216-083-00	METAL CHIP	27K 5% 1/10W (25:B/40:B)			< VIBRATOR >	
R982	1-216-089-91	RES,CHIP	47K 5% 1/10W (25:B/40:B)	X160	1-579-463-11	VIBRATOR, CRYSTAL 32.768KHz	
R983	1-216-067-00	METAL CHIP	5.6K 5% 1/10W (25:B/40:B)	X161	1-577-289-11	VIBRATOR, CRYSTAL 17.734475KHz	
				X200	1-579-608-11	VIBRATOR, CRYSTAL 4.43MHz	
R985	1-216-041-00	METAL CHIP	470 5% 1/10W (25:B/40:B)	△	1-468-271-31	POWER BLOCK ETXNY165E1D ***** (Ref.No.:9,000 Series)	
R986	1-216-089-91	RES,CHIP	47K 5% 1/10W (25:B/40:B)			< CAPACITOR >	
R988	1-216-073-00	METAL CHIP	10K 5% 1/10W (25:B/40:B)	C102	1-216-964-11	ELECT	10uF 50V
R989	1-216-049-91	RES,CHIP	1K 5% 1/10W (25:B/40:B)	C107	1-216-965-11	ELECT	22uF 50V
R990	1-216-295-91	SHORT	0 (25:B/40:B)	C201	1-216-968-11	ELECT	100uF 50V
				C301	9-880-907-01	ELECT	820uF 25V
				C302	1-216-968-11	ELECT	100uF 50V

<p>Note : The components identified by mark △ or dotted line with mark △ are critical for safety. Replace only with part number specified.</p>	<p>Note : Les composants identifiés par une marque △ sont critiques pour la sécurité. Ne les remplacer que par une pièce portant le numéro spécifié.</p>
---	---

POWER BLOCK ETXNY165E1D

Ref. No.	Part No.	Description	Remarks
C401	9-880-908-01	ELECT	820uF 16V
C402	1-126-925-11	ELECT	470uF 10V
C501	1-126-960-11	ELECT	1uF 50V
C601	9-880-909-01	ELECT	330uF 25V
< DIODE >			
D001	8-719-066-97	DIODE	1N4007
D002	8-719-066-97	DIODE	1N4007
D003	8-719-066-97	DIODE	1N4007
D004	8-719-066-97	DIODE	1N4007
D101	9-880-910-01	DIODE	1SS130T-77
D102	9-880-911-01	DIODE	FE1E
D103	9-880-912-01	DIODE	BYV36E
D104	9-880-913-01	DIODE	1SS130T-77
D201	9-880-914-01	DIODE	FE1E
D301	9-880-915-01	DIODE	FE3C
D401	9-880-916-01	DIODE	SB260
D601	9-880-917-01	DIODE	FE1E
< IC >			
IC101	9-880-919-01	IC	UC3844A
IC501	9-880-920-01	IC	KA431AZTA
< PHOTOCOUPLER >			
△PC101	9-880-921-01	PHOTOCOUPLER	LTV817BM-V
< TRANSISTOR >			
Q101	9-880-922-01	POWER FET	SSS2N90-A
Q102	8-729-423-29	TRANSISTOR	2SC3311A-QTA
< VARISTOR >			
△Z001	9-880-923-01	METALOXID-VARISTOR	S10K460
< ZENER DIODE >			
ZD101	9-880-924-01	ZENER DIODE	RD5.1
ZD102	9-880-925-01	ZENER DIODE	RD24JSB3T
ZD103	9-880-926-01	VOLTAGE SUPPRESSOR	P6KE350CA
MISCELLANEOUS *****			
△14	1-777-854-21	CORD, POWER	
19	1-762-844-21	SWITCH, ROTARY	(30,45:EE)
△25	1-770-019-12	ADAPTOR, CONVERSION PLUG	3P
△52	1-468-271-31	POWER BLOCK ETXNY165E1D	
704	1-500-144-11	HEAD, FE	
704	1-500-471-11	HEAD, FE	
776	1-759-791-11	DRUM ASSY, DZH-78D-R	(10/X10/20:VP1,VP2/25:B/30:EE)
776	1-759-793-11	DRUM ASSY, DZH-92B-R	(20:EX,Ux/25:CP,VC/X25/30:CP,Ux,VC1,VC2,X25)
776	1-759-795-11	DRUM ASSY, DZH-93B-R	(40/X40/45)
832	1-766-723-21	CONNECTOR, BOARD TO BOAR	3P
M902	1-698-971-11	MOTOR, DC	
M903	X-3947-577-1	MOTOR ASSY, CAM	

Ref. No.	Part No.	Description	Remarks
ACCESSORIES & PACKING MATERIALS *****			
	1-418-007-11	COMMANDER, STANDARD (RMT-V256)	(10,X10,30:EE)
	1-418-007-21	COMMANDER, STANDARD (RMT-V256A)	(40:EE)
	1-418-008-11	COMMANDER, STANDARD (RMT-V257)	(20:VP1,VP2)
	1-418-008-21	COMMANDER, STANDARD (RMT-V257A)	(25:B)
	1-418-008-31	COMMANDER, STANDARD (RMT-V257B)	(EG/20:EX,Ux/25:CP,VC,X25,40:CP,EG,VC1,VC2/X40)
	1-418-008-41	COMMANDER, STANDARD (RMT-V257C)	(40:B)
	1-418-010-11	COMMANDER, STANDARD (RMT-V259)	(30:CP,Ux,VC2,VC1/45)
	1-696-593-11	CORD, CONNECTION (PAL)	(FOR RF 1.5m)
	3-865-171-11	MANUAL, INSTRUCTION (FRENCH)	(10:AE1)
	3-865-171-21	MANUAL, INSTRUCTION (SPANISH)	(10:AE2)
	3-865-171-31	MANUAL, INSTRUCTION (GERMAN)	(10:AE1)
	3-865-171-41	MANUAL, INSTRUCTION (ITALIAN)	(10:AE1)
	3-865-171-51	MANUAL, INSTRUCTION (DUTCH)	(10:AE1)
	3-865-171-61	MANUAL, INSTRUCTION (PORTUGUESE)	(10:AE2)
	3-865-172-11	MANUAL, INSTRUCTION (SWEDISH)	(10:AE2)
	3-865-172-21	MANUAL, INSTRUCTION (DANISH)	(10:AE2)
	3-865-172-31	MANUAL, INSTRUCTION (FINNISH)	(10:AE2)
	3-865-172-41	MANUAL, INSTRUCTION (GREEK)	(10:AE1)
	3-865-173-11	MANUAL, INSTRUCTION (ENGLISH)	(40:EG)
	3-865-173-21	MANUAL, INSTRUCTION (POLISH)	(40:EG)
	3-865-173-31	MANUAL, INSTRUCTION (CZECH)	(40:EG)
	3-865-173-41	MANUAL, INSTRUCTION (HUNGARIAN)	(40:EG)
	3-865-174-11	MANUAL, INSTRUCTION (ENGLISH)	(10:EG,X10)
	3-865-174-21	MANUAL, INSTRUCTION (POLISH)	(10:EG,X10)
	3-865-174-31	MANUAL, INSTRUCTION (HUNGARIAN)	(10:EG,X10)
	3-865-174-41	MANUAL, INSTRUCTION (HUNGARIAN)	(10:EG,X10)
	3-865-175-11	MANUAL, INSTRUCTION (ENGLISH)	(10:EE/40:EE)
	3-865-175-21	MANUAL, INSTRUCTION (RUSSIAN)	(10:EE/40:EE)
	3-865-274-11	MANUAL, INSTRUCTION (ENGLISH)	(30:EE)
	3-865-274-21	MANUAL, INSTRUCTION (RUSSIAN)	(30:EE)
	3-865-275-11	MANUAL, INSTRUCTION (ENGLISH)	(X40)
	3-865-275-21	MANUAL, INSTRUCTION (POLISH)	(X40)
	3-865-275-31	MANUAL, INSTRUCTION (CZECH)	(X40)
	3-865-275-41	MANUAL, INSTRUCTION (HUNGARIAN)	(X40)
	3-865-359-11	MANUAL, INSTRUCTION (FRENCH)	(30:VC1/45:VC)
	3-865-359-21	MANUAL, INSTRUCTION (SPANISH)	(30:CP)
	3-865-359-31	MANUAL, INSTRUCTION (GERMAN)	(30:VC1/45:VC)
	3-865-359-41	MANUAL, INSTRUCTION (ITALIAN)	(30:CP/45:CP,VC1)

Note :

The components identified by mark △ or dotted line with mark △ are critical for safety. Replace only with part number specified.

Note :

Les composants identifiés par une marque △ sont critiques pour la sécurité. Ne les remplacer que par une pièce portant le numéro spécifié.

Ref. No.	Part No.	Description	Remarks	Ref. No.	Part No.	Description	Remarks
							(40:VC2,X25)
3-865-359-51		MANUAL, INSTRUCTION (DUTCH)	(30:VC1/45:VC)	3-865-363-31		MANUAL, INSTRUCTION (FINNISH)	(40:VC2,X25)
3-865-359-61		MANUAL, INSTRUCTION (PORUGUESE)	(30:VC2)	3-865-363-41		MANUAL, INSTRUCTION (GREEK)	(40:CP)
3-865-360-11		MANUAL, INSTRUCTION (SWEDISH)	(30:VC2)	3-865-364-11		MANUAL, INSTRUCTION (FRENCH)	(40:B/25:B)
3-865-360-21		MANUAL, INSTRUCTION (DANISH)	(30:VC2)	3-865-365-11		MANUAL, INSTRUCTION (ENGLISH)	(20:EX,UX)
3-865-360-31		MANUAL, INSTRUCTION (FINNISH)	(30:VC2)	3-865-439-11		MANUAL, INSTRUCTION (FRENCH)	(20:VP1)
3-865-360-41		MANUAL, INSTRUCTION (GREEK)	(30:CP/45:CP)	3-865-439-21		MANUAL, INSTRUCTION (GERMAN)	(20:VP1)
3-865-361-11		MANUAL, INSTRUCTION (ENGLISH)	(30:UX/45:UX)	3-865-439-31		MANUAL, INSTRUCTION (ITALIAN)	(20:VP1)
3-865-362-11		MANUAL, INSTRUCTION (FRENCH)	(25:VC/40:VC1)	3-865-439-41		MANUAL, INSTRUCTION (DUTCH)	(20:VP1)
3-865-362-21		MANUAL, INSTRUCTION (SPANISH)	(25:CP/40:CP/X25)	3-865-439-51		MANUAL, INSTRUCTION (SWEDISH)	(20:VP2)
3-865-362-31		MANUAL, INSTRUCTION (GERMAN)	(25:VC/40:VC1/X25)	3-865-439-61		MANUAL, INSTRUCTION (DANISH)	(20:VP2)
3-865-362-41		MANUAL, INSTRUCTION (ITALIAN)	(40:CP,VC1/25:VC)	3-865-439-71		MANUAL, INSTRUCTION (FINNISH)	(20:VP2)
3-865-362-51		MANUAL, INSTRUCTION (DUTCH)	(25:VC/40:VC1)	***** HARDWARE LIST *****			
3-865-362-61		MANUAL, INSTRUCTION (PORTUGUESE)	(40:VC2)	#1	7-685-648-79	SCREW +BVTP 3 × 12 TYPE2	
3-865-363-11		MANUAL, INSTRUCTION (SWEDISH)	(40:VC2,X25)	#701	7-685-646-79	SCREW +BVTP 3 × 8 TYPE2 IT-3	
3-865-363-21		MANUAL, INSTRUCTION (DANISH)		#702	7-682-147-01	SCREW +P 3 × 6	
				#703	7-685-133-19	SCREW (DIA. 2.6) (IT3B)	

